

# DOLPHIN LB 0857-1757 A

Liquid ring vacuum pumps



VACUUM SOLUTIONS



## Robust

Proven technology, durable two-stage construction

## Reliable

Extremely high vapor and particle tolerance

## Flexible

Wide range of construction materials, including cast iron (EN-GJL-200), many grades of stainless steel and even titanium, ATEX-certified version available (Cat 1(i)/2(o) IIC T5), operating fluids other than water possible, operation as compressor possible

Accessories, spare parts and options

- Partial or total recirculation systems
- Liquid separator
- Cavitation protection
- Heat exchanger
- Gas ejector
- Wide selection of motors
- Non-return valves
- Vacuum relief valves

# DOLPHIN LB 0857-1757 A

Liquid ring vacuum pumps



VACUUM SOLUTIONS

Dimensional drawing

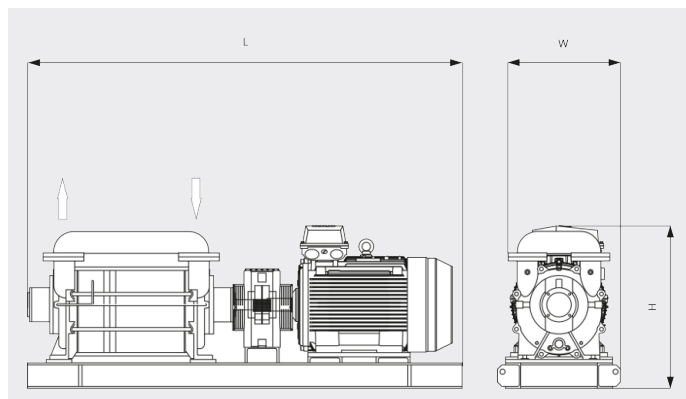

Pumping speed

Air at 20°C. Tolerance: ± 10%

— 50 Hz ..... 60 Hz

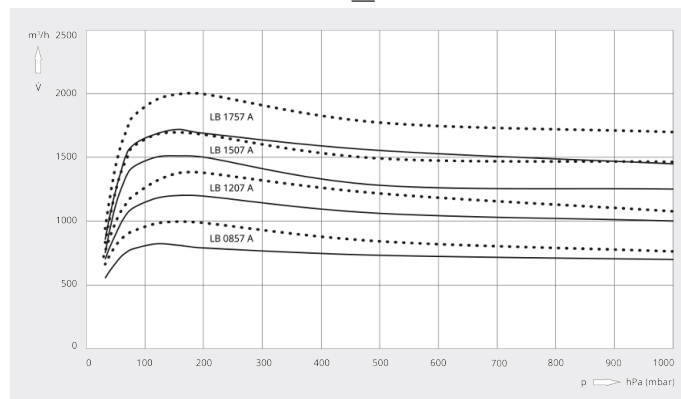

	DOLPHIN LB 0857 A	DOLPHIN LB 1207 A	DOLPHIN LB 1507 A	DOLPHIN LB 1757 A
<b>Nominal pumping speed</b>	850 / 1000 m <sup>3</sup> /h (50 / 60 Hz)	1200 / 1380 m <sup>3</sup> /h (50 / 60 Hz)	1500 / 1690 m <sup>3</sup> /h (50 / 60 Hz)	1750 / 2000 m <sup>3</sup> /h (50 / 60 Hz)
<b>Ultimate pressure</b>	33 hPa (mbar) (50 / 60 Hz)	33 hPa (mbar) (50 / 60 Hz)	33 hPa (mbar) (50 / 60 Hz)	33 hPa (mbar) (50 / 60 Hz)
<b>Max. overpressure</b>	2 bar(g) (50 / 60 Hz)	2 bar(g) (50 / 60 Hz)	2 bar(g) (50 / 60 Hz)	2 bar(g) (50 / 60 Hz)
<b>Nominal motor rating</b>	30 / 37 kW (50 / 60 Hz)	37 / 55 kW (50 / 60 Hz)	45 / 75 kW (50 / 60 Hz)	75 / 90 kW (50 / 60 Hz)
<b>Nominal motor speed</b>	960 / 1150 min <sup>-1</sup> (50 / 60 Hz)	960 / 1150 min <sup>-1</sup> (50 / 60 Hz)	960 / 1150 min <sup>-1</sup> (50 / 60 Hz)	960 / 1150 min <sup>-1</sup> (50 / 60 Hz)
<b>Noise level (ISO 2151)</b>	76 / 77 dB(A)	76 / 77 dB(A)	76 / 77 dB(A)	76 / 77 dB(A)
<b>Weight approx.</b>	510 kg	600 kg	685 kg	770 kg
<b>Dimensions (L x W x H)</b>	( 1096 – 1282 ) x 610 x 750 mm	( 1246 – 1432 ) x 610 x 750 mm	( 1346 – 1532 ) x 610 x 750 mm	( 1496 – 1682 ) x 610 x 750 mm
<b>Gas inlet / outlet</b>	DN 100 PN 10 / DN 100 PN 10	DN 100 PN 10 / DN 100 PN 10	DN 100 PN 10 / DN 100 PN 10	DN 100 PN 10 / DN 100 PN 10

## DO YOU WANT TO KNOW MORE?

Get in touch with us directly!  
[info@busch.ca](mailto:info@busch.ca) or +1 800 363 6360



CONTACT FORM



CALL NOW