

DOLPHIN LB 0857-1757 A

Liquid ring vacuum pumps



VACUUM SOLUTIONS



Robust

Proven technology, durable two-stage construction

Reliable

Extremely high vapor and particle tolerance

Flexible

Wide range of construction materials, including cast iron (EN-GJL-200), many grades of stainless steel and even titanium, ATEX-certified version available (Cat 1(i)/2(o) IIC T5), operating fluids other than water possible, operation as compressor possible

Accessories, spare parts and options

- Partial or total recirculation systems
- Liquid separator
- Cavitation protection
- Heat exchanger
- Gas ejector
- Wide selection of motors
- Non-return valves
- Vacuum relief valves

DOLPHIN LB 0857-1757 A

Liquid ring vacuum pumps



VACUUM SOLUTIONS

Dimensional drawing

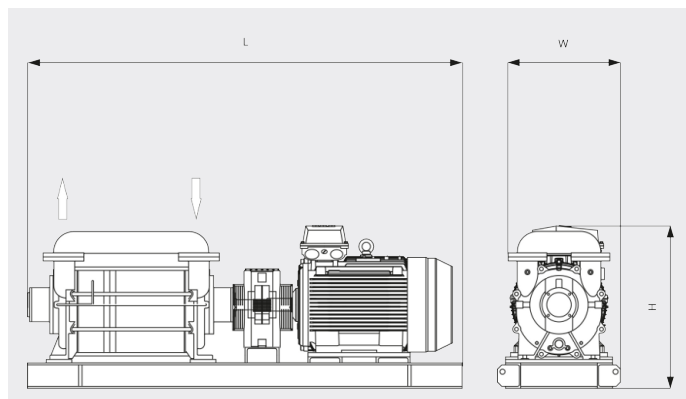

Pumping speed

Air at 20°C. Tolerance: ± 10%

— 50 Hz 60 Hz

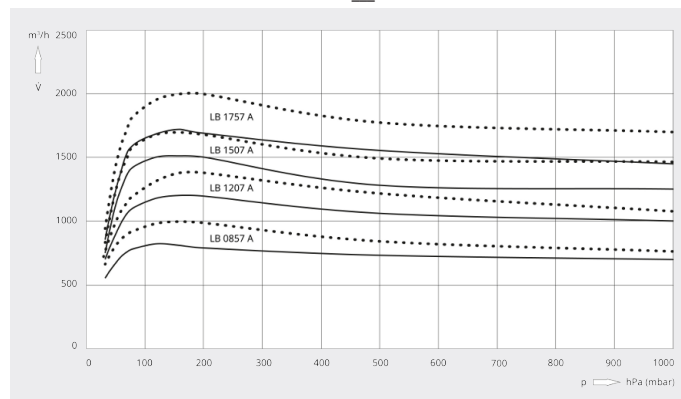

	DOLPHIN LB 0857 A	DOLPHIN LB 1207 A	DOLPHIN LB 1507 A	DOLPHIN LB 1757 A
Nominal pumping speed	850 / 1000 m³/h (50 / 60 Hz)	1200 / 1380 m³/h (50 / 60 Hz)	1500 / 1690 m³/h (50 / 60 Hz)	1750 / 2000 m³/h (50 / 60 Hz)
Ultimate pressure	33 hPa (mbar) (50 / 60 Hz)	33 hPa (mbar) (50 / 60 Hz)	33 hPa (mbar) (50 / 60 Hz)	33 hPa (mbar) (50 / 60 Hz)
Max. overpressure	2 bar(g) (50 / 60 Hz)	2 bar(g) (50 / 60 Hz)	2 bar(g) (50 / 60 Hz)	2 bar(g) (50 / 60 Hz)
Nominal motor rating	30 / 37 kW (50 / 60 Hz)	37 / 55 kW (50 / 60 Hz)	45 / 75 kW (50 / 60 Hz)	75 / 90 kW (50 / 60 Hz)
Nominal motor speed	960 / 1150 min ⁻¹ (50 / 60 Hz)	960 / 1150 min ⁻¹ (50 / 60 Hz)	960 / 1150 min ⁻¹ (50 / 60 Hz)	960 / 1150 min ⁻¹ (50 / 60 Hz)
Noise level (ISO 2151)	76 / 77 dB(A)	76 / 77 dB(A)	76 / 77 dB(A)	76 / 77 dB(A)
Weight approx.	510 kg	600 kg	685 kg	770 kg
Dimensions (L x W x H)	(1096 – 1282) x 610 x 750 mm	(1246 – 1432) x 610 x 750 mm	(1346 – 1532) x 610 x 750 mm	(1496 – 1682) x 610 x 750 mm
Gas inlet / outlet	DN 100 PN 10 / DN 100 PN 10	DN 100 PN 10 / DN 100 PN 10	DN 100 PN 10 / DN 100 PN 10	DN 100 PN 10 / DN 100 PN 10

DOLPHIN LB 0857-1757 A

Liquid ring vacuum pumps



VACUUM SOLUTIONS

	DOLPHIN LB 0857 A	DOLPHIN LB 1207 A	DOLPHIN LB 1507 A	DOLPHIN LB 1757 A
Nominal pumping speed	586.0 ACFM	813.0 ACFM	995.0 ACFM	1177.0 ACFM
Ultimate pressure	25 TORR	25 TORR	25 TORR	25 TORR
Max. overpressure	29.0 PSIG	29.0 PSIG	29.0 PSIG	29.0 PSIG
Nominal motor rating	60.0 HP	75.0 HP	100.0 HP	125.0 HP
Nominal motor speed	1150 RPM	1150 RPM	1150 RPM	1150 RPM
Noise level (ISO 2151)	77 dB(A)	77 dB(A)	77 dB(A)	77 dB(A)
Weight approx.	1190 Lbs.	1323 Lbs.	1510 Lbs.	1698 Lbs.
Dimensions (L x W x H)	50.5 x 18.9 x 27.9 inches	56.4 x 18.9 x 27.9 inches	60.3 x 19 x 27 inches	66.3 x 18.9 x 27.9 inches
Gas inlet / outlet	4" ANSI / 4" ANSI	4" ANSI / 4" ANSI	4" ANSI / 4" ANSI	4" ANSI / 4" ANSI

DO YOU WANT TO KNOW MORE?

Get in touch with us directly!
info@busch.ca or +1 800 363 6360



CONTACT FORM



CALL NOW