

DOLPHIN LB 2108-3108 A

Liquid ring vacuum pumps



VACUUM SOLUTIONS



Robust

Proven technology, durable two-stage construction

Reliable

Extremely high vapor and particle tolerance

Flexible

Wide range of construction materials, including cast iron (EN-GJL-200), many grades of stainless steel and even titanium, ATEX-certified version available (Cat 1(i)/2(o) IIC T5), operating fluids other than water possible, operation as compressor possible

Accessories, spare parts and options

- Partial or total recirculation systems
- Liquid separator
- Cavitation protection
- Heat exchanger
- Gas ejector
- Wide selection of motors
- Non-return valves
- Vacuum relief valves

DOLPHIN LB 2108-3108 A

Liquid ring vacuum pumps



VACUUM SOLUTIONS

Dimensional drawing

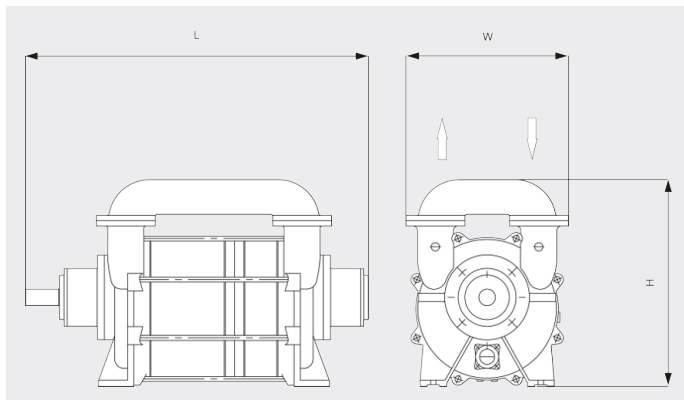

Pumping speed

Air at 20°C. Tolerance: ± 10%

— 50 Hz 60 Hz

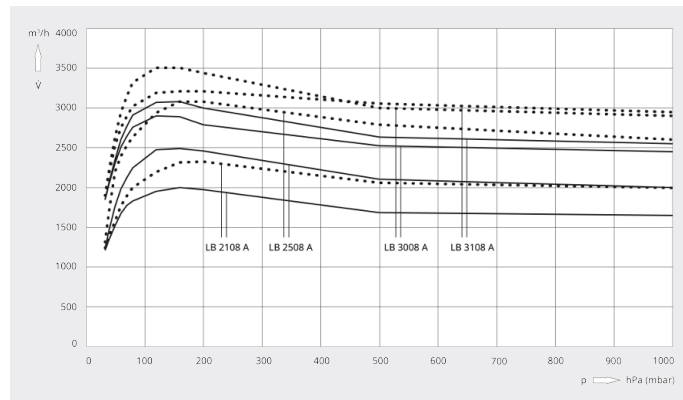

	DOLPHIN LB 2108 A	DOLPHIN LB 2508 A	DOLPHIN LB 3008 A	DOLPHIN LB 3108 A
Nominal pumping speed	2100 m ³ /h (50 / 60 Hz)	2500 m ³ /h (50 / 60 Hz)	3000 m ³ /h (50 / 60 Hz)	3100 m ³ /h (50 / 60 Hz)
Ultimate pressure	33 hPa (mbar)	33 hPa (mbar)	33 hPa (mbar)	33 hPa (mbar)
Nominal motor rating	55 kW	75 kW	90 kW	110 kW
Nominal motor speed	735 min ⁻¹ (50 / 60 Hz)	880 min ⁻¹ (50 / 60 Hz)	735 min ⁻¹ (50 / 60 Hz)	735 min ⁻¹ (50 / 60 Hz)
Noise level (ISO 2151)	79 dB(A)	79 dB(A)	79 dB(A)	79 dB(A)
Weight approx.	1526 kg	1664 kg	1800 kg	2090 kg
Dimensions (L x W x H)	(1658 – 1938) x 650 x 800 mm	(1808 – 2088) x 650 x 800mm	(1908 – 2188) x 650 x 800 mm	(1943 – 2223) x 650 x 800 mm
Gas inlet / outlet	DN 150 PN 10 / DN 150 PN 10	DN 150 PN 10 / DN 150 PN 10	DN 150 PN 10 / DN 150 PN 10	DN 150 PN 10 / DN 150 PN 10

DOLPHIN LB 2108-3108 A

Liquid ring vacuum pumps



VACUUM SOLUTIONS

	DOLPHIN LB 2108 A	DOLPHIN LB 2508 A	DOLPHIN LB 3008 A	DOLPHIN LB 3108 A
Nominal pumping speed	1368.0 ACFM	1813.0 ACFM	1889.0 ACFM	2063.0 ACFM
Ultimate pressure	25 TORR	25 TORR	25 TORR	25 TORR
Nominal motor rating	125.0 HP	150.0 HP	200.0 HP	200.0 HP
Nominal motor speed	880 RPM	880 RPM	880 RPM	880 RPM
Noise level (ISO 2151)	79 dB(A)	79 dB(A)	79 dB(A)	79 dB(A)
Weight approx.	3219 Lbs.	3483 Lbs.	3748 Lbs.	4277 Lbs.
Dimensions (L x W x H)	76.3 x 25.6 x 39.4 inches	82.2 x 25.6 x 39.4 inches	86.1 x 25.6 x 39.4 inches	87.5 x 25.6 x 39.4 inches
Gas inlet / outlet	6" / 6"	6" / 6"	6" / 6"	6" / 6"

DO YOU WANT TO KNOW MORE?

Get in touch with us directly!
info@busch.ca or +1 800 363 6360



CONTACT FORM



CALL NOW