

PANDA WV 0250/0500 C

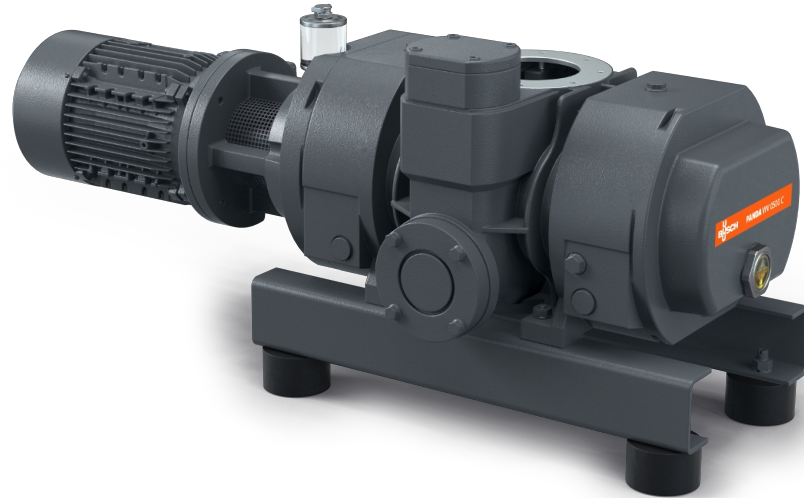

Reliable

Solid lobe design, robust construction, reliable under varying operating conditions, barrier gas connection

High performance

Excellent volumetric efficiency, high ultimate pressure, increases the performance of a vacuum system by up to a factor of ten, integrated bypass valve, specially designed for rough and medium vacuum applications

Flexible

Can be flanged directly on the system at any position, boosts the performance of all types of backing pumps, with vertical or lateral discharge, perfectly suited for chemical processes

PANDA WV 0250/0500 C

Dimensional drawing

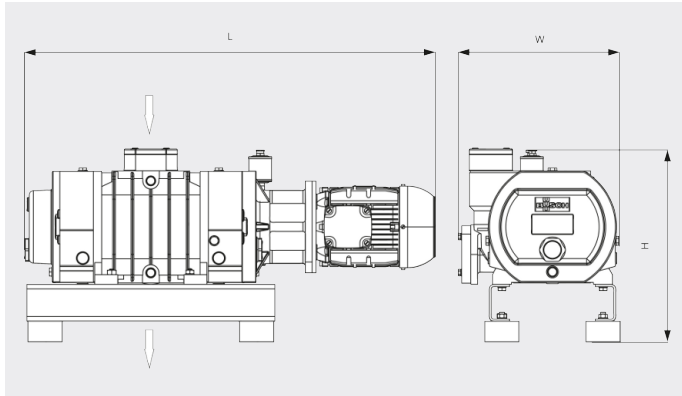

Pumping speed

Air at 20°C. Tolerance: ± 10%

— 50 Hz 60 Hz

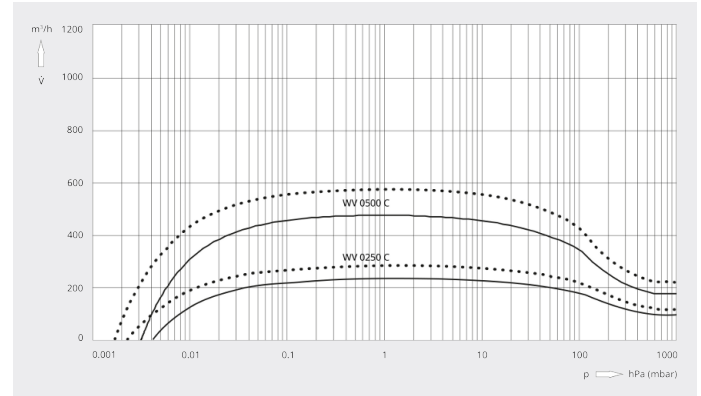

	PANDA WV 0250 C	PANDA WV 0500 C
Nominal pumping speed	250 / 300 m³/h (50 / 60 Hz)	500 / 600 m³/h (50 / 60 Hz)
Pumping speed	235 / 285 m³/h (50 / 60 Hz)	480 / 575 m³/h (50 / 60 Hz)
Max. differential pressure	85 hPa (mbar) (50 / 60 Hz)	85 hPa (mbar) (50 / 60 Hz)
Nominal motor rating	1.1 / 1.5 kW (50 / 60 Hz)	2.2 / 3.0 kW (50 / 60 Hz)
Nominal motor speed	1500 / 1800 min ⁻¹ (50 / 60 Hz)	3000 / 3600 min ⁻¹ (50 / 60 Hz)
Weight approx.	150 kg	150 kg
Dimensions (L x W x H)	904 x 352 x 422 mm	917 x 352 x 422 mm
Gas inlet / outlet (vertical)	DN 100 ISO / DN 100 ISO	DN 100 ISO / DN 100 ISO

PANDA WV 0250/0500 C



	PANDA WV 0250 C	PANDA WV 0500 C
Nominal pumping speed	176.6 ACFM	353.1 ACFM
Pumping speed	167.7 ACFM	338.4 ACFM
Max. differential pressure	75 TORR	75 TORR
Nominal motor rating	2.0 HP	4.0 HP
Nominal motor speed	1800 RPM	3600 RPM
Weight approx.	330 Lbs.	330 Lbs.
Dimensions (L x W x H)	35.6 x 13.9 x 16.6 inches	36.1 x 13.9 x 16.6 inches
Gas inlet / outlet (vertical)	DN 100 ISO / DN 100 ISO	DN 100 ISO / DN 100 ISO
Gas inlet / outlet (horizontal)	DN 100 ISO / DN 063 ISO	DN 100 ISO / DN 063 ISO

DO YOU WANT TO KNOW MORE?

Get in touch with us directly!
info@busch.ca or +1 800 363 6360



CONTACT FORM



CALL NOW