

PANDA WV 1200-2400 A

Vacuum boosters

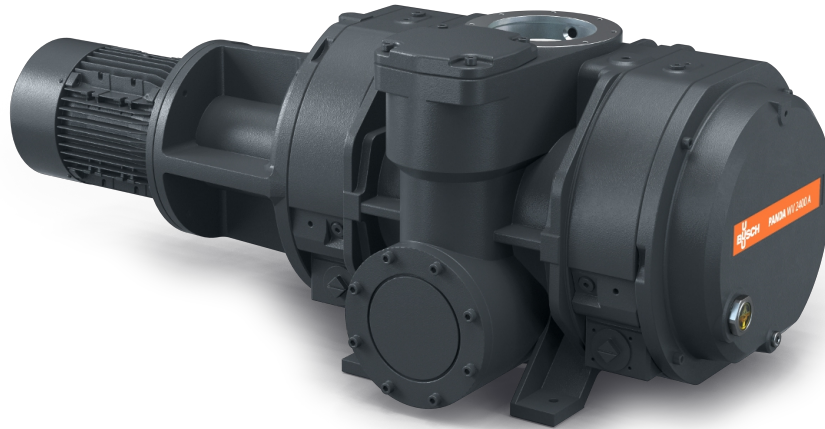

VACUUM SOLUTIONS



Reliable

Solid lobe design, robust construction made of GGG40 material, reliable under varying operating conditions, barrier gas connection, standard mechanical shaft seals, perfectly suited for chemical processes

High performance

Excellent volumetric efficiency, high ultimate pressure, increases the performance of a vacuum system by up to a factor of ten, integrated bypass valve, specially designed for rough and medium vacuum applications

Flexible

Can be flanged directly on the system at any position, boosts the performance of all types of backing pumps, with vertical or lateral discharge

PANDA WV 1200-2400 A

Vacuum boosters



VACUUM SOLUTIONS

Dimensional drawing

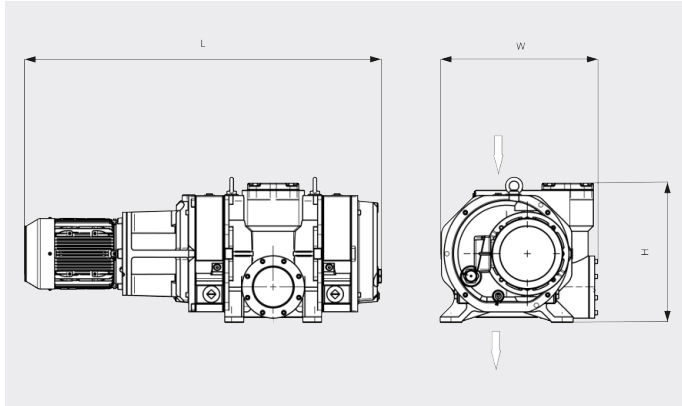

Pumping speed

Air at 20°C. Tolerance: ± 10%

— 50 Hz 60 Hz

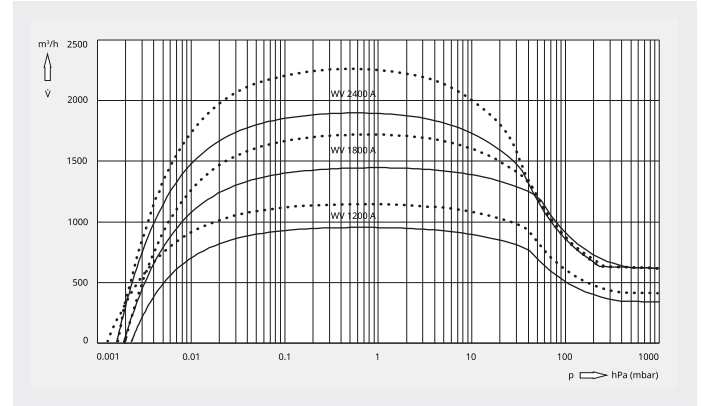

	PANDA WV 1200 A	PANDA WV 1800 A	PANDA WV 2400 A
Nominal pumping speed	1050 / 1260 m³/h (50 / 60 Hz)	1600 / 1920 m³/h (50 / 60 Hz)	2120 / 2540 m³/h (50 / 60 Hz)
Pumping speed	950 / 1141 m³/h (50 / 60 Hz)	1443 / 1718 m³/h (50 / 60 Hz)	1920 / 2290 m³/h (50 / 60 Hz)
Max. differential pressure	53 hPa (mbar) (50 / 60 Hz)	53 hPa (mbar) (50 / 60 Hz)	53 hPa (mbar) (50 / 60 Hz)
Nominal motor rating	3.5 / 4.8 kW (50 / 60 Hz)	4.3 / 5.2 kW (50 / 60 Hz)	5.5 / 7.0 kW (50 / 60 Hz)
Nominal motor speed	3000 / 3600 min ⁻¹ (50 / 60 Hz)	3000 / 3600 min ⁻¹ (50 / 60 Hz)	3000 / 3600 min ⁻¹ (50 / 60 Hz)
Weight approx.	290 kg	300 kg	520 kg
Dimensions (L x W x H)	1094 x 470 x 353 mm	1114 x 470 x 398 mm	1286 x 568 x 503 mm
Gas inlet / outlet (vertical)	DN 160 ISO / DN 100 ISO	DN 160 ISO / DN 100 ISO	DN 160 ISO / DN 160 ISO

PANDA WV 1200 A: Pumping speed with COBRA NC 0400 as backing pump
 PANDA WV 1800/2400 A: Pumping speed with COBRA NC 0630 as backing pump

PANDA WV 1200-2400 A

Vacuum boosters



VACUUM SOLUTIONS

	PANDA WV 1200 A	PANDA WV 1800 A	PANDA WV 2400 A
Nominal pumping speed	742.0 ACFM	1130.0 ACFM	1495.0 ACFM
Pumping speed	672.0 ACFM	1011.0 ACFM	1348.0 ACFM
Max. differential pressure	40 TORR	40 TORR	40 TORR
Nominal motor rating	5.0 HP	7.5 HP	10.0 HP
Nominal motor speed	3600 RPM	3600 RPM	3600 RPM
Weight approx.	639 Lbs.	661 Lbs.	1146 Lbs.
Dimensions (L x W x H)	45.7 x 18.5 x 19.6 inches	46.7 x 18.5 x 21.4 inches	52.9 x 22.4 x 24.9 inches
Gas inlet / outlet (vertical)	ANSI 4" / ANSI 4"	ANSI 4" / ANSI 4"	ANSI 6" / ANSI 4"
Gas inlet / outlet (horizontal)	ANSI 4" / ANSI 4"	ANSI 4" / ANSI 4"	ANSI 6" / ANSI 4"

DO YOU WANT TO KNOW MORE?

Get in touch with us directly!
info@busch.ca or +1 800 363 6360



CONTACT FORM



CALL NOW