

# RANGU DF 1000-2800 A

Diffusion vacuum pumps



VACUUM SOLUTIONS



## Reliable

Robust construction, perfectly suited for demanding processes, nearly maintenance-free

## High performance

Designed for all industrial high vacuum applications, such as glass coating, vacuum furnaces, metal coating, high and stable pumping speeds under varying conditions, inlet pressure  $\leq 10^{-3}$  hPa (mbar)

## Quiet

Low noise and vibration levels

# RANGU DF 1000-2800 A

Diffusion vacuum pumps



VACUUM SOLUTIONS

Dimensional drawing

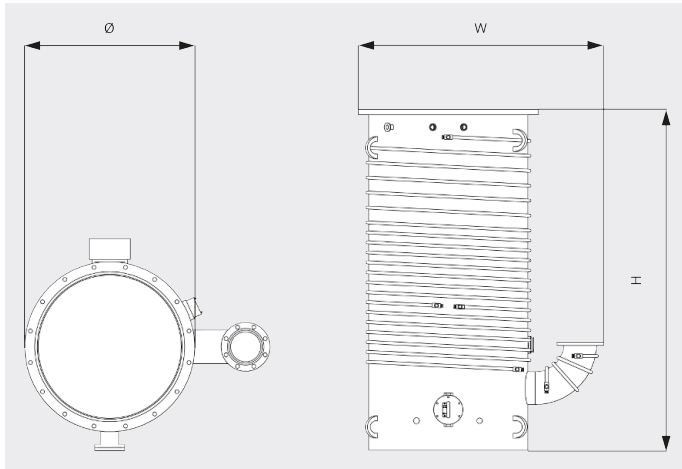

Pumping speed

Air at 20°C. Tolerance: ± 10%

— 50 Hz    ..... 60 Hz

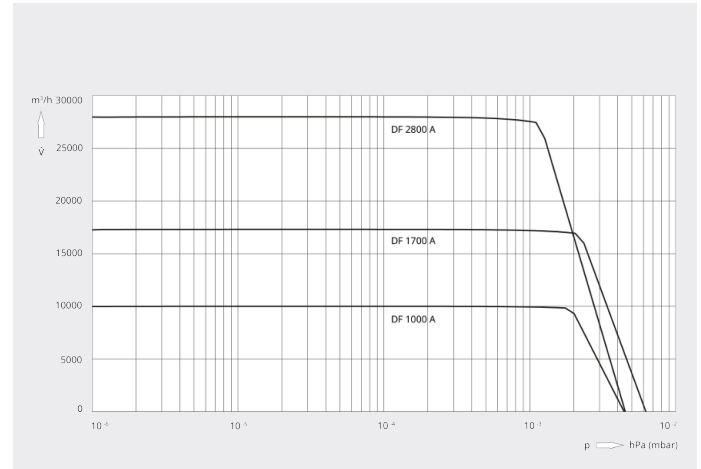

	RANGU DF 1000 A	RANGU DF 1700 A	RANGU DF 2800 A
Nominal pumping speed for N <sub>2</sub>	10000 l/s	17300 l/s	28000 l/s
Recommended size of backing pump	170 m <sup>3</sup> /h	510 m <sup>3</sup> /h	510 m <sup>3</sup> /h
Ultimate pressure	< 7 · 10 <sup>-8</sup> hPa (mbar)	< 7 · 10 <sup>-8</sup> hPa (mbar)	< 7 · 10 <sup>-8</sup> hPa (mbar)
Max. foreline pressure for N <sub>2</sub>	0.86 hPa (mbar)	0.66 hPa (mbar)	0.73 hPa (mbar)
Operating power	12 kW	24 kW	24 kW
Cooling water consumption	6 l/min	15 l/min	15 l/min
Required cooling water temperature	15 - 26 °C	15 - 26 °C	15 - 26 °C
Warm-up time	45 min	60 min	60 min
Operating fluid charge	4.7 l	11.4 l	11.4 l
Weight approx.	272 kg	682 kg	682 kg

# RANGU DF 1000-2800 A

Diffusion vacuum pumps



VACUUM SOLUTIONS

	RANGU DF 1000 A	RANGU DF 1700 A	RANGU DF 2800 A
Dimensions (W x H x Ø)	1070 x 1219 x 690 mm	1253 x 1740 x 920 mm	1753 x 1832 x 1120 mm
Gas inlet / outlet	DN 630 ISO-K / DN 160 ISO-K	DN 800 ISO-K / DN 200 ISO-K	DN 1000 ISO-K / DN 200 ISO-K

## DO YOU WANT TO KNOW MORE?

Get in touch with us directly!  
[info@busch.ca](mailto:info@busch.ca) or +1 800 363 6360



CONTACT FORM



CALL NOW