

COBRA NX 0450/0650 A

Dry screw vacuum pumps



VACUUM SOLUTIONS



High performance

Advanced screw design, patented self-balancing screws, perfectly suited for heat treatment, coating, vacuum packaging, vacuum drying and degassing

Efficient

Low cost of ownership, minimal maintenance, long service intervals, high uptime, efficient water cooling

Flexible

Modular design, easy combination with PANDA vacuum boosters for increased ultimate pressure and pumping speed

Accessories

- Sealing gas supply for seals used with applications particularly subject to damp or dust
- Gas-ballast valve for increased water vapor tolerance
- Exhaust gas silencer for reduced sound level
- Radiator cooling system

COBRA NX 0450/0650 A

Dry screw vacuum pumps



VACUUM SOLUTIONS

Dimensional drawing

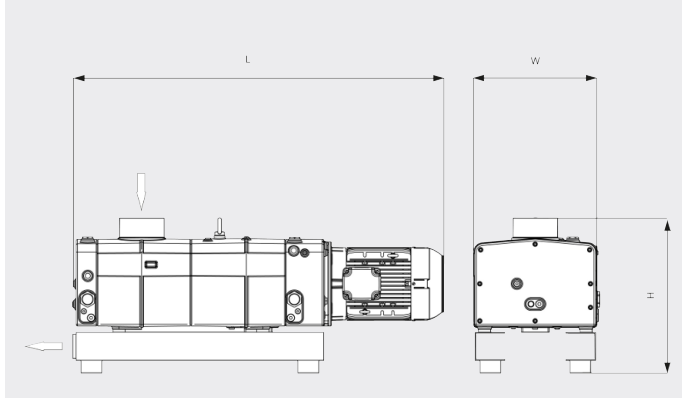

Pumping speed

Air at 20°C. Tolerance: ± 10%

— 50 Hz 60 Hz

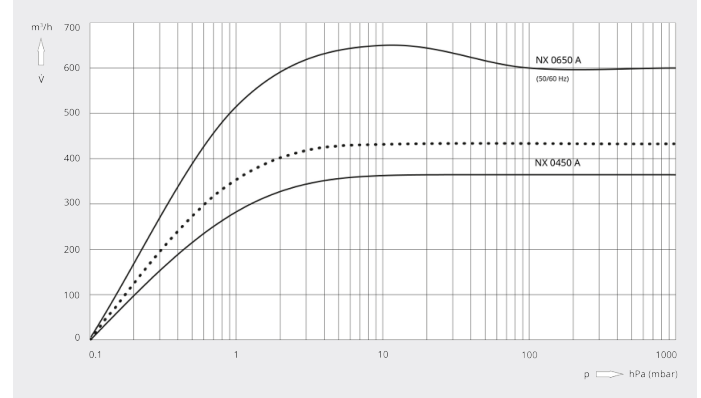

	COBRA NX 0450 A	COBRA NX 0650 A
Nominal pumping speed	350 / 420 m³/h (50 / 60 Hz)	650 m³/h (50 / 60 Hz)
Ultimate pressure	≤ 0.1 hPa (mbar) (50 / 60 Hz)	≤ 0.1 hPa (mbar) (50 / 60 Hz)
Nominal motor rating	7.5 / 9.5 kW (50 / 60 Hz)	12.5 / 15.0 kW (50 / 60 Hz)
Nominal motor speed	3000 / 3600 min ⁻¹ (50 / 60 Hz)	3000 / 3600 min ⁻¹ (50 / 60 Hz)
Noise level (ISO 2151)	65 / 70 dB(A) (50 / 60 Hz)	71 / 75 dB(A) (50 / 60 Hz)
Weight approx.	500 kg	700 kg
Dimensions (L x W x H)	1321 x 450 x 551 mm	1521 x 524 x 623 mm
Gas inlet / outlet	G 3"/ ISO-F DN 100 / G 2"/ ISO-F DN 63	G 3"/ ISO-F DN 100 / G 3"/ ISO-F DN 100

COBRA NX 0450/0650 A

Dry screw vacuum pumps



VACUUM SOLUTIONS

	COBRA NX 0450 A	COBRA NX 0650 A
Nominal pumping speed	247 ACFM	383 ACFM
Ultimate pressure	≤ 0.075 TORR	≤ 0.075 TORR
Nominal motor rating	12.7 HP	22.8 HP
Nominal motor speed	3600 RPM	3600 RPM
Noise level (ISO 2151)	70 dB(A)	75 dB(A)
Weight approx.	1100 Lbs.	1540 Lbs.
Dimensions (L x W x H)	24.5 x 17.8 x 21.7 inches	59.9 x 20.6 x 24.5 inches
Gas inlet / outlet	G 3" ISO-F DN 100 / G 2" ISO-F DN 63	G 3" ISO-F DN 100 / G 3" ISO-F DN 100

DO YOU WANT TO KNOW MORE?

Get in touch with us directly!
info@busch.ca or +1 800 363 6360



CONTACT FORM



CALL NOW