

DOLPHIN LM 0100-0270 A

Liquid ring vacuum pumps and compressors



VACUUM SOLUTIONS



Robust

Proven technology, durable single-stage construction, corrosion-free stainless steel impeller, direct flange-mounted motor, no base frame required, integrated flow channel

Reliable

Extremely high vapor and particle tolerance, optimized gas flow

Flexible

Choice of cast iron (EN-GJL-200) or 316 grade stainless steel material housings, ATEX-certified version available (Cat 1(i/o) IIC T4), operating fluids other than water possible

Accessories

- Modular pumpsets, configured for once-through, partial or total recirculation of the operating fluid
- Liquid separator
- Cavitation protection
- Heat exchanger
- Gas ejector
- Wide selection of motors
- Non-return valves
- Vacuum relief valves
- Variable speed drive (only for LM 0180/0270 A)

DOLPHIN LM 0100-0270 A

Liquid ring vacuum pumps and compressors



VACUUM SOLUTIONS

Dimensional drawing

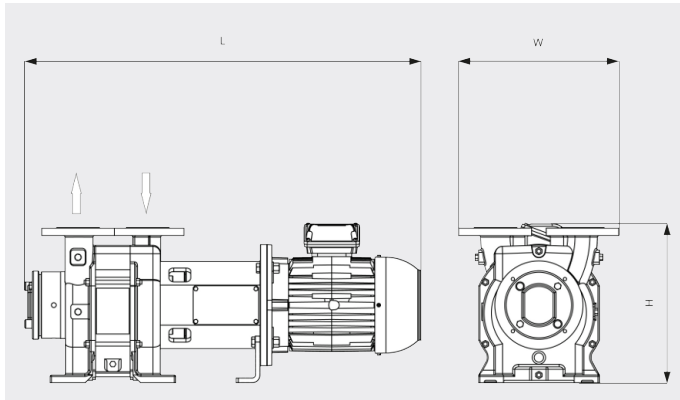

Pumping speed

Dry air at 20 °C. Operating fluid water 15°C. Tolerance: - 10%, in accordance with HEI and Pneurop 6612

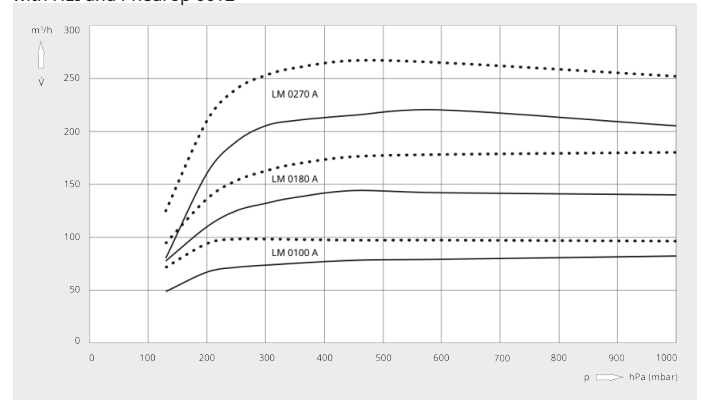

	DOLPHIN LM 0100 A	DOLPHIN LM 0180 A	DOLPHIN LM 0270 A
Nominal pumping speed	82 / 98 m³/h (50 / 60 Hz)	144 / 180 m³/h (50 / 60 Hz)	220 / 267 m³/h (50 / 60 Hz)
Ultimate pressure	130 hPa (mbar) (50 / 60 Hz)	130 hPa (mbar) (50 / 60 Hz)	130 hPa (mbar) (50 / 60 Hz)
Max. overpressure	0.8 bar(g) (50 / 60 Hz)	1.5 bar(g) (50 / 60 Hz)	1.5 bar(g) (50 / 60 Hz)
Nominal motor rating	2.2 / 3.0 kW (50 / 60 Hz)	4.0 / 5.5 kW (50 / 60 Hz)	5.5 / 7.5 kW (50 / 60 Hz)
Nominal motor speed	1450 / 1750 min ⁻¹ (50 / 60 Hz)	1450 / 1750 min ⁻¹ (50 / 60 Hz)	1450 / 1750 min ⁻¹ (50 / 60 Hz)
Noise level (ISO 2151)	70 / 71 dB(A) (50 / 60 Hz)	70 / 71 dB(A) (50 / 60 Hz)	70 / 71 dB(A) (50 / 60 Hz)
Weight approx.	110 kg	122 kg	157 kg
Dimensions (L x W x H)	811 x 330 x 329 mm	879 x 330 x 351 mm	988 x 330 x 380 mm
Gas inlet / outlet	DN 40 PN 10 / DN 40 PN 10	DN 40 PN 10 / DN 40 PN 10	DN 40 PN 10 / DN 40 PN 10

DOLPHIN LM 0100-0270 A

Liquid ring vacuum pumps and compressors



VACUUM SOLUTIONS

	DOLPHIN LM 0100 A	DOLPHIN LM 0180 A	DOLPHIN LM 0270 A
Nominal pumping speed	58.0 ACFM	106.0 ACFM	157.0 ACFM
Ultimate pressure	100 TORR	100 TORR	100 TORR
Nominal motor rating	5.0 HP	7.5 HP	10.0 HP
Nominal motor speed	1800 RPM	1800 RPM	1800 RPM
Noise level (ISO 2151)	71 dB(A)	71 dB(A)	71 dB(A)
Weight approx.	275 Lbs.	349 Lbs.	374 Lbs.
Dimensions (L x W x H)	36 x 13.4 x 12.6 inches	39.2 x 14.4 x 12.6 inches	42.6 x 14.3 x 42.6 inches
Gas inlet / outlet	DN 40 PN 10 / ANSI 1½" / 150 lbs / JIS 40 10K / DN 40 PN 10 / ANSI 1½" / 150 lbs / JIS 40 10K	DN 40 PN 10 / ANSI 1½" / 150 lbs / JIS 40 10K / DN 40 PN 10 / ANSI 1½" / 150 lbs / JIS 40 10K	DN 40 PN 10 / ANSI 1½" / 150 lbs / JIS 40 10K / DN 40 PN 10 / ANSI 1½" / 150 lbs / JIS 40 10K

DO YOU WANT TO KNOW MORE?

Get in touch with us directly!
info@busch.ca or +1 800 363 6360



CONTACT FORM



CALL NOW