

DOLPHIN LT 0130-0220 A

Liquid ring vacuum pumps



VACUUM SOLUTIONS



Robust

Proven technology, durable two-stage construction, corrosion-free stainless steel impeller, direct flange-mounted motor, no base frame required, integrated flow channel

Reliable

Extremely high vapor and particle tolerance, optimized gas flow

Flexible

Choice of cast iron (EN-GJL-200) or 316 grade stainless steel material housings, ATEX-certified version available (Cat 1G (i) 2G (o) IIC T4), operating fluids other than water possible

Accessories

- Modular pumpsets, configured for once-through, partial or total recirculation of the operating fluid
- Liquid separator
- Cavitation protection
- Heat exchanger
- Gas ejector
- Wide selection of motors
- Non-return valves
- Vacuum relief valves
- Variable speed drive (only for LT 0170/0220 A)

DOLPHIN LT 0130-0220 A

Liquid ring vacuum pumps



VACUUM SOLUTIONS

Dimensional drawing

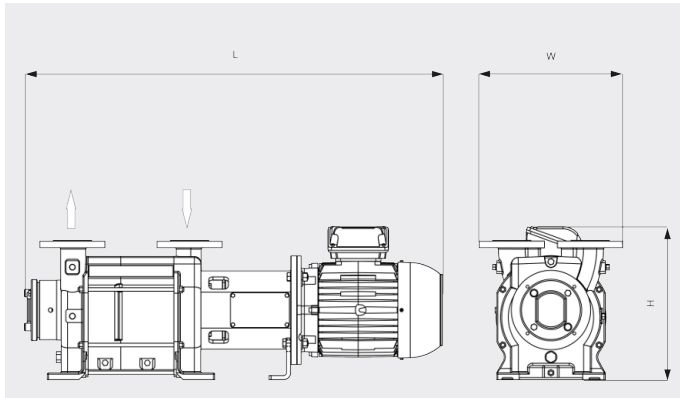

Pumping speed

Dry air at 20 °C. Operating fluid water 15°C. Tolerance: - 10%, in accordance with HEI and Pneurop 6612

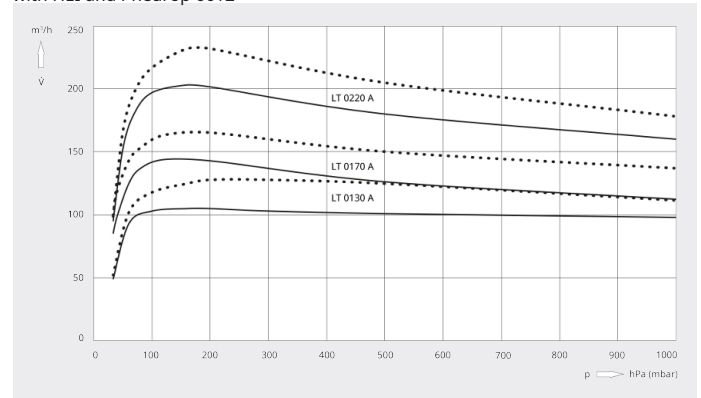

	DOLPHIN LT 0130 A	DOLPHIN LT 0170 A	DOLPHIN LT 0220 A
Nominal pumping speed	105 / 128 m ³ /h (50 / 60 Hz)	144 / 165 m ³ /h (50 / 60 Hz)	203 / 232 m ³ /h (50 / 60 Hz)
Ultimate pressure	33 hPa (mbar) (50 / 60 Hz)	33 hPa (mbar) (50 / 60 Hz)	33 hPa (mbar) (50 / 60 Hz)
Max. overpressure	1.5 bar(g) (50 / 60 Hz)	1.5 bar(g) (50 / 60 Hz)	1.2 bar(g) (50 / 60 Hz)
Nominal motor rating	3.0 / 4.0 kW (50 / 60 Hz)	4.0 / 5.5 kW (50 / 60 Hz)	5.5 / 7.5 kW (50 / 60 Hz)
Nominal motor speed	1450 / 1750 min ⁻¹ (50 / 60 Hz)	1450 / 1750 min ⁻¹ (50 / 60 Hz)	1450 / 1750 min ⁻¹ (50 / 60 Hz)
Noise level (ISO 2151)	70 / 71 dB(A) (50 / 60 Hz)	70 / 71 dB(A) (50 / 60 Hz)	70 / 71 dB(A) (50 / 60 Hz)
Weight approx.	139 kg	149 kg	188 kg
Dimensions (L x W x H)	906 x 330 x 329 mm	954 x 330 x 351 mm	1083 x 330 x 380 mm
Gas inlet / outlet	DN 40 PN 10 / DN 40 PN 10	DN 40 PN 10 / DN 40 PN 10	DN 40 PN 10 / DN 40 PN 10

DOLPHIN LT 0130-0220 A

Liquid ring vacuum pumps



VACUUM SOLUTIONS

	DOLPHIN LT 0130 A	DOLPHIN LT 0170 A	DOLPHIN LT 0220 A
Nominal pumping speed	75.0 ACFM	97.0 ACFM	137.0 ACFM
Ultimate pressure	25 TORR	25 TORR	25 TORR
Nominal motor rating	5.0 HP	7.5 HP	10.0 HP
Nominal motor speed	1800 RPM	1800 RPM	1800 RPM
Noise level (ISO 2151)	71 dB(A)	71 dB(A)	71 dB(A)
Weight approx.	303 Lbs.	367 Lbs.	401 Lbs.
Dimensions (L x W x H)	39.8 x 13.4 x 12.6 inches	42.1 x 14.4 x 12.6 inches	46.4 x 15.1 x 12.6 inches
Gas inlet / outlet	DN 40 PN 10 / ANSI 1½" / 150 lbs / JIS 40 10K / DN 40 PN 10 / ANSI 1½" / 150 lbs / JIS 40 10K	DN 40 PN 10 / ANSI 1½" / 150 lbs / JIS 40 10K / DN 40 PN 10 / ANSI 1½" / 150 lbs / JIS 40 10K	DN 40 PN 10 / ANSI 1½" / 150 lbs / JIS 40 10K / DN 40 PN 10 / ANSI 1½" / 150 lbs / JIS 40 10K

DO YOU WANT TO KNOW MORE?

Get in touch with us directly!
info@busch.ca or +1 800 363 6360



CONTACT FORM



CALL NOW