

DOLPHIN LX 0110-0180 C

Liquid ring vacuum pumps

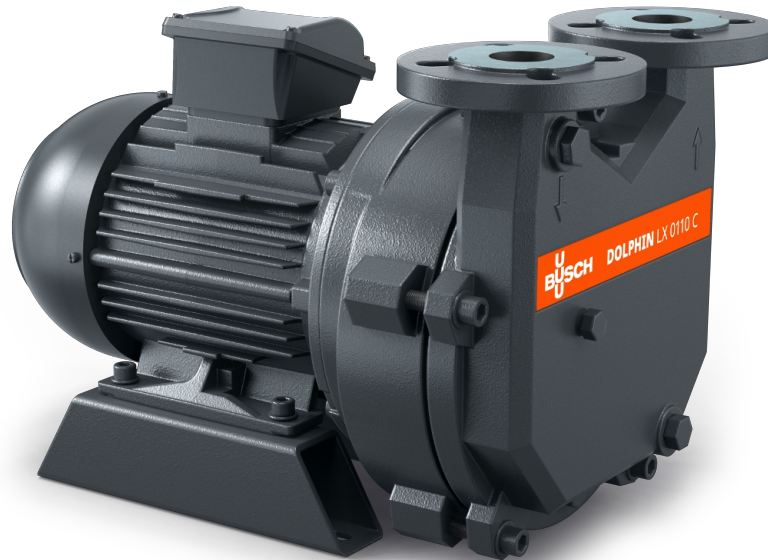

VACUUM SOLUTIONS



Robust

Proven technology, reliable operation, extremely high particle and vapor tolerance, corrosion-free stainless steel impeller

Compact

Directly flanged motor, no base frame required

Flexible

Choice of cast iron (EN-GJL-200) or 316 grade stainless steel material housings, ATEX-certified version available (Cat. 2 (i) IIB, T4), operating fluids other than water possible

Accessories

- Partial or total recirculation systems
- Liquid separator
- Cavitation protection
- Heat exchanger
- Gas ejector
- Wide selection of motors
- Non-return valves
- Vacuum relief valves
- Different operating fluids possible

DOLPHIN LX 0110-0180 C

Liquid ring vacuum pumps



VACUUM SOLUTIONS

Dimensional drawing

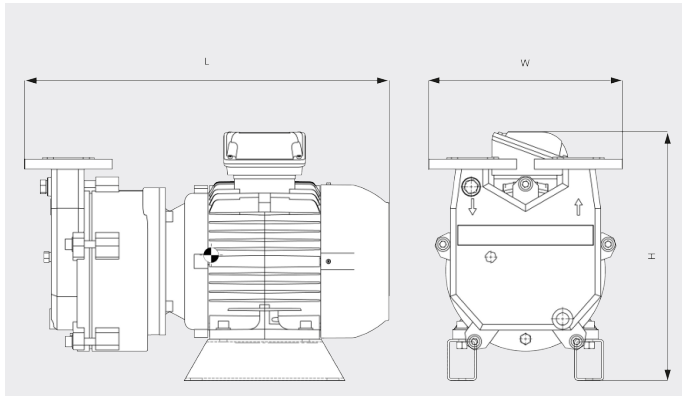

Pumping speed

Dry air at 20 °C. Operating fluid water 15°C. Tolerance: - 10%, in accordance with HEI and Pneurop 6612

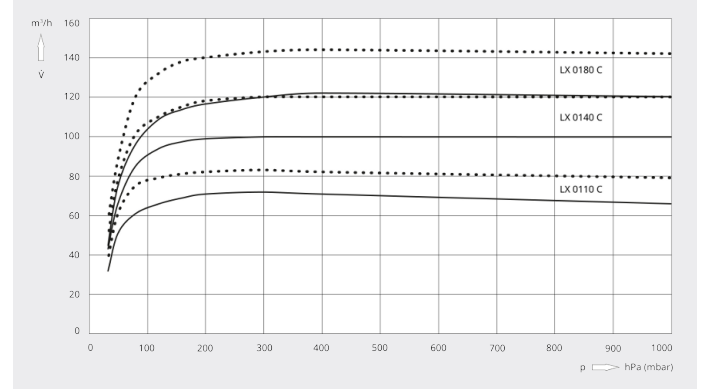

	DOLPHIN LX 0110 C	DOLPHIN LX 0140 C	DOLPHIN LX 0180 C
Nominal pumping speed	72 / 83 m³/h (50 / 60 Hz)	100 / 120 m³/h (50 / 60 Hz)	122 / 144 m³/h (50 / 60 Hz)
Ultimate pressure	33 hPa (mbar) (50 / 60 Hz)	33 hPa (mbar) (50 / 60 Hz)	33 hPa (mbar) (50 / 60 Hz)
Nominal motor rating	2.2 / 3.0 kW (50 / 60 Hz)	3.0 / 4.0 kW (50 / 60 Hz)	4.0 / 5.5 kW (50 / 60 Hz)
Weight approx.	76 / 83 kg (50 / 60 Hz)	86 / 92 kg (50 / 60 Hz)	95 / 112 kg (50 / 60 Hz)
Dimensions (L x W x H)	517 x 330 x 347 mm	568 x 330 x 347 mm	564 x 330 x 374 mm
Gas inlet / outlet	DN 40 PN 16 / DN 40 PN 16	DN 40 PN 16 / DN 40 PN 16	DN 40 PN 16 / DN 40 PN 16

DOLPHIN LX 0110-0180 C

Liquid ring vacuum pumps



VACUUM SOLUTIONS

	DOLPHIN LX 0110 C	DOLPHIN LX 0140 C	DOLPHIN LX 0180 C
Nominal pumping speed	48.8 ACFM	70.6 ACFM	84.7 ACFM
Ultimate pressure	25 TORR	25 TORR	25 TORR
Nominal motor rating	4.0 HP	5.4 HP	7.4 HP
Weight approx.	122 Lbs.	144 Lbs.	206 Lbs.
Dimensions (L x W x H)	20.4 x 13 x 13.7 inches	21.4 x 13 x 14.1 inches	24.5 x 13 x 16.6 inches
Gas inlet / outlet	1½" ANSI / 1½" ANSI	1½" ANSI / 1½" ANSI	1½" ANSI / 1½" ANSI

DO YOU WANT TO KNOW MORE?

Get in touch with us directly!
info@busch.ca or +1 800 363 6360



CONTACT FORM



CALL NOW