

DOLPHIN LX 0260-0430 C

Liquid ring vacuum pumps



VACUUM SOLUTIONS



Robust

Proven technology, reliable operation, extremely high particle and vapor tolerance, corrosion-free stainless steel impeller

Compact

Directly flanged motor, no base frame required

Flexible

Choice of cast iron (EN-GJL-200) or 316 grade stainless steel material housings, ATEX-certified version available (Cat. 2 (i) IIB, T4), operating fluids other than water possible

DOLPHIN LX 0260-0430 C

Liquid ring vacuum pumps



VACUUM SOLUTIONS

Dimensional drawing

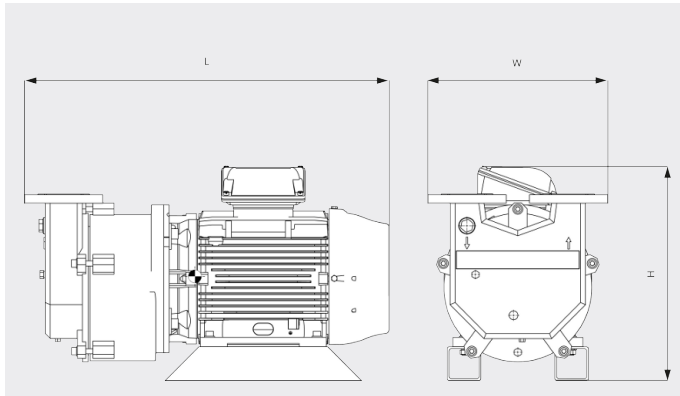

Pumping speed

Dry air at 20 °C. Operating fluid water 15°C. Tolerance: - 10%, in accordance with HEI and Pneurop 6612

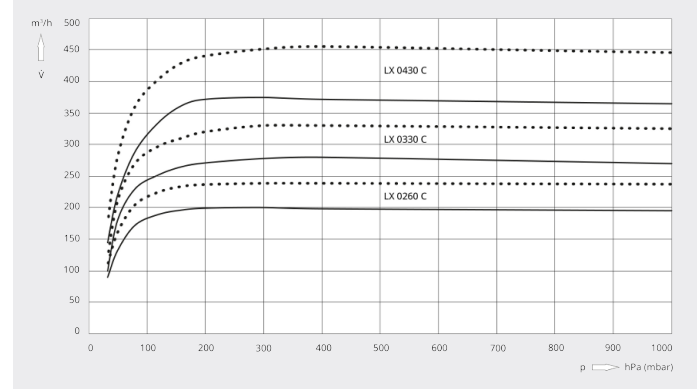

	DOLPHIN LX 0260 C	DOLPHIN LX 0330 C	DOLPHIN LX 0430 C
Nominal pumping speed	200 / 239 m ³ /h (50 / 60 Hz)	280 / 330 m ³ /h (50 / 60 Hz)	375 / 455 m ³ /h (50 / 60 Hz)
Ultimate pressure	33 hPa (mbar) (50 / 60 Hz)	33 hPa (mbar) (50 / 60 Hz)	33 hPa (mbar) (50 / 60 Hz)
Nominal motor rating	5.5 / 7.5 kW (50 / 60 Hz)	7.5 / 11.0 kW (50 / 60 Hz)	11.0 / 15.0 kW (50 / 60 Hz)
Nominal motor speed	1450 / 1750 min ⁻¹ (50 / 60 Hz)	1450 / 1750 min ⁻¹ (50 / 60 Hz)	1450 / 1750 min ⁻¹ (50 / 60 Hz)
Noise level (ISO 2151)	72 dB(A) (50 / 60 Hz)	72 dB(A) (50 / 60 Hz)	72 dB(A) (50 / 60 Hz)
Weight approx.	135 / 145 kg (50 / 60 Hz)	147 / 198 kg (50 / 60 Hz)	227 / 247 kg (50 / 60 Hz)
Dimensions (L x W x H)	635 x 365 x 402 mm	706 x 365 x 402 mm	818 x 425 x 506 mm
Gas inlet / outlet	DN 50 PN16 / DN 50 PN16	DN 50 PN16 / DN 50 PN16	DN 65 PN16 / DN 65 PN16

DOLPHIN LX 0260-0430 C

Liquid ring vacuum pumps



VACUUM SOLUTIONS

	DOLPHIN LX 0260 C	DOLPHIN LX 0330 C	DOLPHIN LX 0430 C
Nominal pumping speed	140.7 ACFM	194.2 ACFM	267.8 ACFM
Ultimate pressure	25 TORR	25 TORR	25 TORR
Nominal motor rating	10.0 HP	15.0 HP	20.0 HP
Nominal motor speed	1750 RPM	1750 RPM	1750 RPM
Noise level (ISO 2151)	72 dB(A)	72 dB(A)	72 dB(A)
Weight approx.	319.7 Lbs.	436.5 Lbs.	544.5 Lbs.
Dimensions (L x W x H)	26.5 x 14.4 x 15.8 inches	27.8 x 14.4 x 15.8 inches	33.9 x 16.7 x 19.9 inches
Gas inlet / outlet	2" ANSI / 2" ANSI	2" ANSI / 2" ANSI	2½" ANSI / 2½" ANSI

DO YOU WANT TO KNOW MORE?

Get in touch with us directly!
info@busch.ca or +1 800 363 6360



CONTACT FORM



CALL NOW