

HUCKEPACK HO 0429-0441 F

Once-through oil-lubricated rotary vane vacuum pumps



VACUUM SOLUTIONS



Robust

Reliable operation, proven performance, high vapor and particle tolerance, resistant to sticky and very aggressive substances, fresh oil lubrication for outstanding running qualities, highly resistant carbon fiber composite vanes

Flexible

Specially designed for particularly complex processes, for example in the chemical, pharmaceutical and special food packaging industries, easy adaption to individual customer requirements and processes, ATEX-version available

Easy servicing

Minimal maintenance, no special tools necessary, modular design for rapid exchange of stages

Accessories

- Oil mist separator
- Various inlet filters
- Oil and flushing tank in reinforced plastic or stainless-steel material
- Flushing device, manual and automatic
- Monitoring and safety devices
- Level switch
- Temperature switch
- Pressure switch
- Proximity switch
- Temperature control valve
- Different choices of vanes
- Large choice of lubricants and flushing liquids
- Radiator cooling system
- Duosec safety knock-out 3-phase separator
- Direct or star / delta switching devices
- Exhaust silencer
- Gas-ballast valve
- Silencer
- ATEX certification

HUCKEPACK HO 0429-0441 F

Once-through oil-lubricated rotary vane vacuum pumps



VACUUM SOLUTIONS

Dimensional drawing

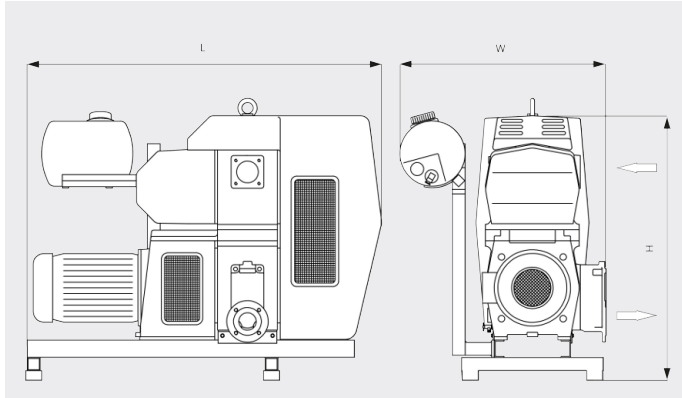

Pumping speed

Air at 20°C. Tolerance: ± 10%

— 50 Hz 60 Hz

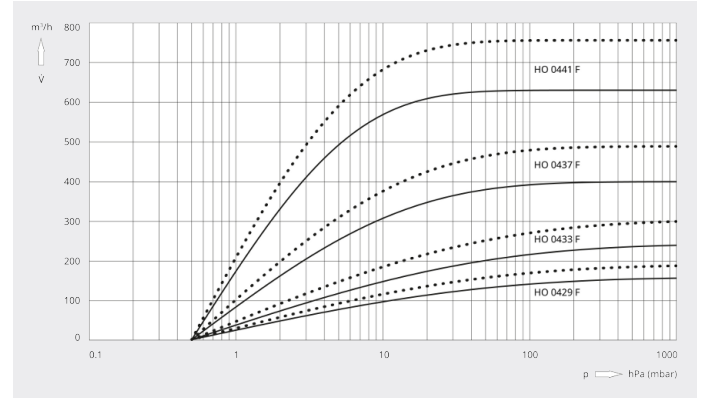

	HUCKEPACK HO 0429 F	HUCKEPACK HO 0433 F	HUCKEPACK HO 0437 F	HUCKEPACK HO 0441 F
Nominal pumping speed	160 / 190 m ³ /h (50 / 60 Hz)	250 / 300 m ³ /h (50 / 60 Hz)	400 / 480 m ³ /h (50 / 60 Hz)	630 / 760 m ³ /h (50 / 60 Hz)
Ultimate pressure	0.5 hPa (mbar) (50 / 60 Hz)	0.5 hPa (mbar) (50 / 60 Hz)	0.5 hPa (mbar) (50 / 60 Hz)	0.5 hPa (mbar) (50 / 60 Hz)
Nominal motor rating	5.5 / 9.2 kW (50 / 60 Hz)	7.5 / 9.2 kW (50 / 60 Hz)	11.0 / 15.0 kW (50 / 60 Hz)	15.0 / 18.5 kW (50 / 60 Hz)
Nominal motor speed	1500 / 1800 min ⁻¹ (50 / 60 Hz)	1500 / 1800 min ⁻¹ (50 / 60 Hz)	1000 / 1200 min ⁻¹ (50 / 60 Hz)	1000 / 1200 min ⁻¹ (50 / 60 Hz)
Noise level (ISO 2151)	72 dB(A) (50 / 60 Hz)	73 dB(A) (50 / 60 Hz)	73 dB(A) (50 / 60 Hz)	74 dB(A) (50 / 60 Hz)
Weight approx.	385 kg	440 kg	930 kg	1000 kg
Dimensions (L x W x H)	1320 x 740 x 1160 mm	1320 x 740 x 1160 mm	1640 x 950 x 1240 mm	1640 x 950 x 1240 mm
Gas inlet / outlet	DN 80 / DN 50	DN 80 / DN 50	DN 80 / DN 80	DN 80 / DN 80

HUCKEPACK HO 0429-0441 F

Once-through oil-lubricated rotary vane vacuum pumps



VACUUM SOLUTIONS

	HUCKEPACK HO 0429 F	HUCKEPACK HO 0433 F	HUCKEPACK HO 0437 F	HUCKEPACK HO 0441 F
Nominal pumping speed	111.8 ACFM	176.6 ACFM	282.5 ACFM	447.3 ACFM
Ultimate pressure	0.375 TORR	0.375 TORR	0.375 TORR	0.375 TORR
Nominal motor rating	10 HP	15 HP	20 HP	25 HP
Nominal motor speed	1800 RPM	1800 RPM	1200 RPM	1200 RPM
Noise level (ISO 2151)	72 dB(A)	73 dB(A)	73 dB(A)	74 dB(A)
Weight approx.	1000 Lbs.	1180 Lbs.	2050 Lbs.	2430 Lbs.
Dimensions (L x W x H)	45.6 x 33.6 x 49.4 inches	46.6 x 36.1 x 49.4 inches	62 x 41.5 x 52 inches	63.8 x 44.3 x 52 inches
Gas inlet / outlet	DN 80 / DN 50	DN 80 / DN 50	DN 80 / DN 80	DN 80 / DN 80

DO YOU WANT TO KNOW MORE?

Get in touch with us directly!
info@busch.ca or +1 800 363 6360



CONTACT FORM



CALL NOW