

MINK MV 0312 B

Dry claw vacuum pump



VACUUM SOLUTIONS



Quiet

Low noise level due to a state-of-the-art acoustic design, can be installed at workstations

Efficient

Latest claw vacuum technology, low energy consumption, minimized operating costs, nearly maintenance-free, effective air cooling

Compact

Small footprint

MINK MV 0312 B

Dry claw vacuum pump



VACUUM SOLUTIONS

Dimensional drawing

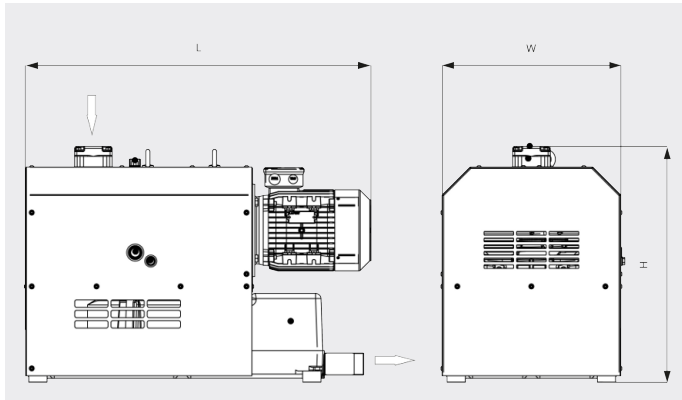

Pumping speed

Air at 20°C. Tolerance: ± 10%

— 50 Hz 60 Hz

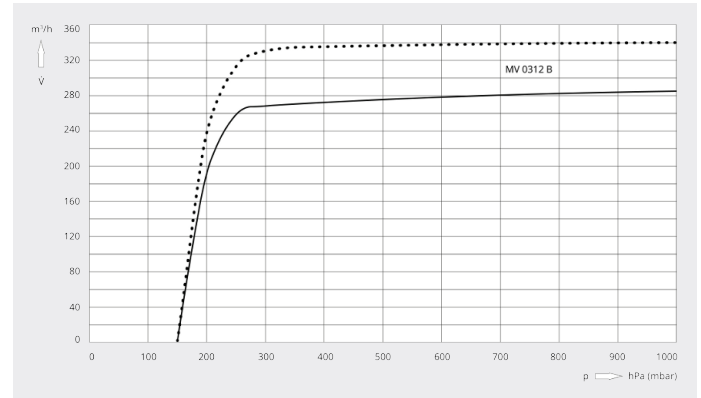

MINK MV 0312 B	
Nominal pumping speed	290 / 345 m³/h (50 / 60 Hz)
Ultimate pressure	150 hPa (mbar) (50 / 60 Hz)
Nominal motor rating	5.5 / 6.5 kW (50 / 60 Hz)
Nominal motor speed	3000 / 3600 min ⁻¹ (50 / 60 Hz)
Noise level (ISO 2151)	69 / 72 dB(A) (50 / 60 Hz)
Weight approx.	300 kg
Dimensions (L x W x H)	940 x 500 x 650 mm
Gas inlet / outlet	G 2" / R 1¼"

MINK MV 0312 B

Dry claw vacuum pump



VACUUM SOLUTIONS

MINK MV 0312 B	
Nominal pumping speed	203 ACFM
Ultimate pressure	112.5 TORR
Nominal motor rating	8.7 HP
Nominal motor speed	3600 RPM
Noise level (ISO 2151)	72 dB(A)
Weight approx.	660 Lbs.
Dimensions (L x W x H)	37 x 19.5 x 25.6 inches
Gas inlet / outlet	G 2" / R 1¼"

DO YOU WANT TO KNOW MORE?

Get in touch with us directly!
info@busch.ca or +1 800 363 6360



CONTACT FORM



CALL NOW