

PUMA WP 1250-4500 B2/D2

Vacuum boosters

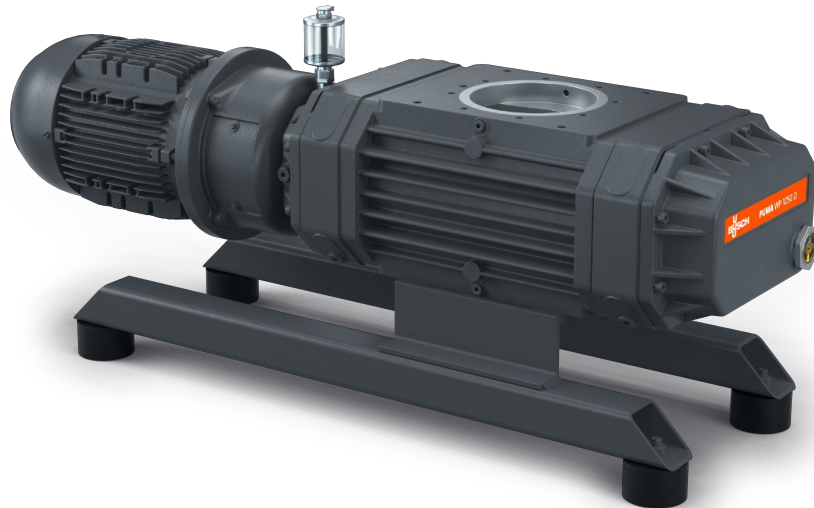

VACUUM SOLUTIONS



Reliable

Solid lobe design, robust construction made of GGG40 material

High performance

Excellent volumetric efficiency, increases the performance of a vacuum system by up to a factor of ten, specially designed for rough and medium vacuum applications

Flexible

Can be flanged directly on the system at any position, boosts the performance of all types of backing pumps, control possible via pressure switch or frequency converter

PUMA WP 1250-4500 B2/D2

Vacuum boosters



VACUUM SOLUTIONS

Dimensional drawing

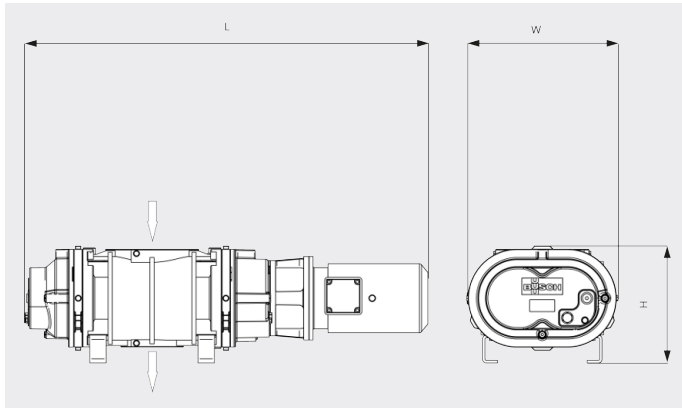

Pumping speed

Air at 20°C. Tolerance: ± 10%

— 50 Hz 60 Hz

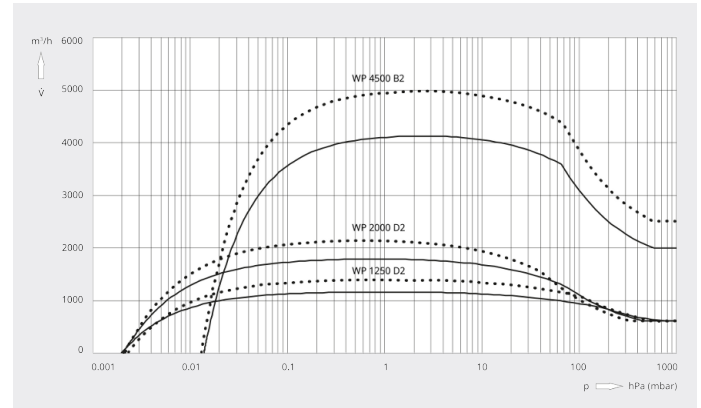

	PUMA WP 1250 D2	PUMA WP 2000 D2	PUMA WP 4500 B2
Nominal pumping speed	1295 / 1555 m ³ /h (50 / 60 Hz)	2020 / 2435 m ³ /h (50 / 60 Hz)	4500 / 5400 m ³ /h (50 / 60 Hz)
Pumping speed	1166 / 1392 m ³ /h (50 / 60 Hz)	1791 / 2136 m ³ /h (50 / 60 Hz)	4126 / 4972 m ³ /h (50 / 60 Hz)
Max. differential pressure	50 hPa (mbar) (50 / 60 Hz)	50 hPa (mbar) (50 / 60 Hz)	25 hPa (mbar) (50 / 60 Hz)
Nominal motor rating	4.3 / 5.2 kW (50 / 60 Hz)	5.5 / 7.0 kW (50 / 60 Hz)	11.0 / 12.6 kW (50 / 60 Hz)
Nominal motor speed	3000 / 3600 min ⁻¹ (50 / 60 Hz)	3000 / 3600 min ⁻¹ (50 / 60 Hz)	3000 / 3600 min ⁻¹ (50 / 60 Hz)
Weight approx.	250 kg	350 kg	640 kg
Dimensions (L x W x H)	1062 x 348 x 490 mm	1156 x 420 x 600 mm	1443 x 544 x 419 mm
Gas inlet / outlet	DN 160 ISO / DN 160 ISO	DN 160 ISO / DN 160 ISO	DN 250 ISO / DN 160 ISO

PUMA WP 1250-4500 B2/D2

Vacuum boosters



VACUUM SOLUTIONS

	PUMA WP 1250 D2	PUMA WP 2000 D2	PUMA WP 4500 B2
Nominal pumping speed	915 ACFM	1435 ACFM	3180 ACFM
Pumping speed	673 ACFM	1247 ACFM	2685 ACFM
Max. differential pressure	30 TORR	30 TORR	18.75 TORR
Nominal motor rating	7 HP	10.2 HP	16.9 HP
Nominal motor speed	3600 RPM	3600 RPM	3600 RPM
Weight approx.	485 Lbs.	730 Lbs.	1235 Lbs.
Dimensions (L x W x H)	41.9 x 12.4 x 19.5 inches	44.8 x 15.4 x 23.9 inches	56.9 x 21.5 x 19 inches
Gas inlet / outlet	DN 160 ISO-F / DN 160 ISO-F	DN 160 ISO-F / DN 160 ISO-F	DN 250 ISO-F / DN 160 ISO-F

DO YOU WANT TO KNOW MORE?

Get in touch with us directly!
info@busch.ca or +1 800 363 6360



CONTACT FORM



CALL NOW