

R5 RA 1000/1600 B

Oil-lubricated rotary vane vacuum pumps



VACUUM SOLUTIONS



Reliable

Robust construction, highly resilient carbon fiber vanes, proven rotary vane technology, long service life

High performance

High pumping speed at low pressures, designed for continuous operation

Flexible

Various design options available, easy adaption to individual customer requirements and processes, level and temperature switch as standard

Accessories

- IEC (IE3) and NEMA motors
- Multi-voltage, multi-frequency motors (IE3)
- Optional variable speed drive
- Single or double gas-ballast valve, manual or solenoid operation
- Various inlet filters
- Inlet filter pressure gauge
- Various temperature and pressure gauges
- Starter units
- Oil mist separator
- Energy recuperation kit with heat exchanger
- Vacuum pump oils for all applications

R5 RA 1000/1600 B

Oil-lubricated rotary vane vacuum pumps



VACUUM SOLUTIONS

Dimensional drawing

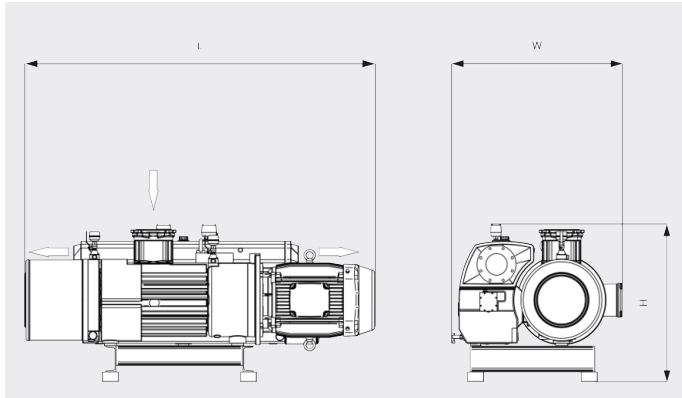

Pumping speed

Air at 20°C. Tolerance: ± 10%

— 50 Hz 60 Hz

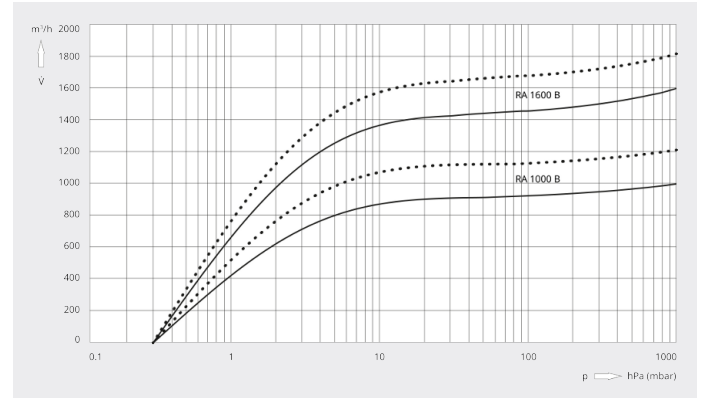

	R5 RA 1000 B	R5 RA 1600 B
Nominal pumping speed	1000 / 1200 m³/h (50 / 60 Hz)	1600 / 1800 m³/h (50 / 60 Hz)
Ultimate pressure	0.3 hPa (mbar) (50 / 60 Hz)	0.3 hPa (mbar) (50 / 60 Hz)
Nominal motor rating	22.0 / 30.0 kW (50 / 60 Hz)	30.0 / 37.0 kW (50 / 60 Hz)
Nominal motor speed	1000 / 1200 min ⁻¹ (50 / 60 Hz)	1000 / 1200 min ⁻¹ (50 / 60 Hz)
Power consumption at 100 mbar	17.3 / 22.4 kW (50 / 60 Hz)	26.8 / 33.0 kW (50 / 60 Hz)
Power consumption at ultimate pressure	9.3 / 12.1 kW (50 / 60 Hz)	13.8 / 17.9 kW (50 / 60 Hz)
Noise level (ISO 2151)	82 dB(A) (50 / 60 Hz)	83 dB(A) (50 / 60 Hz)
Oil capacity	30 l	30 l
Weight approx.	1000 / 1060 kg	1330 / 1350 kg
Dimensions (L x W x H)	1894 x 1003 x 936 mm	2234 x 1040 x 936 mm
Gas inlet / outlet	DN 150 / DN 125	DN 150 / DN 125

R5 RA 1000/1600 B

Oil-lubricated rotary vane vacuum pumps



VACUUM SOLUTIONS

	R5 RA 1000 B	R5 RA 1600 B
Nominal pumping speed	710 ACFM	1060 ACFM
Ultimate pressure	0.225 TORR	0.225 TORR
Nominal motor rating	40 HP	50 HP
Nominal motor speed	1200 RPM	1200 RPM
Power consumption at 75 TORR	30 HP	44.2 HP
Power consumption at ultimate pressure	16.2 HP	24.0 HP
Noise level (ISO 2151)	82 dB(A)	83 dB(A)
Oil capacity	32.0 qts.	32.0 qts.
Weight approx.	2151 Lbs.	2833 Lbs.
Dimensions (L x W x H)	75.3 x 45.3 x 36.8 inches	87.8 x 45.3 x 36.8 inches
Gas inlet / outlet	6" / 4" ANSI / 6" / 4" ANSI	6" / 4" ANSI / 6" / 4" ANSI

DO YOU WANT TO KNOW MORE?

Get in touch with us directly!
info@busch.ca or +1 800 363 6360



CONTACT FORM



CALL NOW