

SECO SD 1063-1100 B/C

Dry-running rotary vane compressors



VACUUM SOLUTIONS



Compact

Direct-drive construction

Reliable

Robust construction, proven performance, self-lubricating vanes, no operating fluids

High performance

High performance Aerodur 274 Zirkon vanes, extended lifetime, extremely resistant to wear and humidity

Accessories

- Inlet filter
- Non-return valve (exhaust)
- Hose nipple
- Pressure relief valve
- Vacuum regulation valve

SECO SD 1063-1100 B/C

Dry-running rotary vane compressors



VACUUM SOLUTIONS

Dimensional drawing

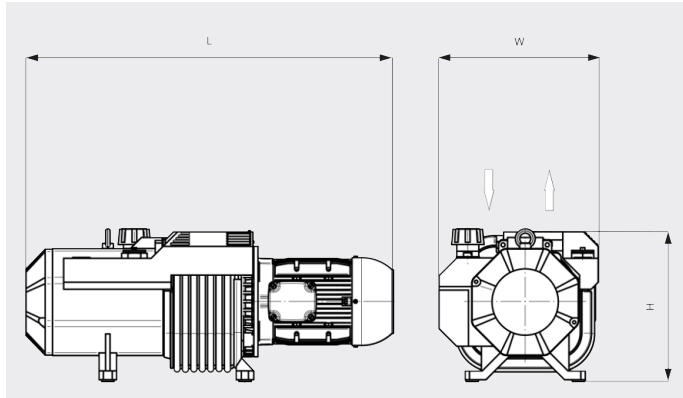

Volume flow

Air at 20°C. Tolerance: ± 10%

— 50 Hz 60 Hz

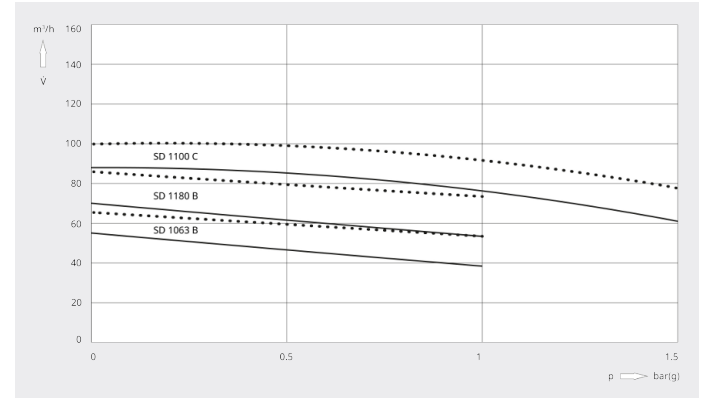

	SECO SD 1063 B	SECO SD 1080 B	SECO SD 1100 C
Volume flow	55 / 65 m³/h (50 / 60 Hz)	70 / 86 m³/h (50 / 60 Hz)	88 / 100 m³/h (50 / 60 Hz)
Overpressure	1.0 bar(g) (50 / 60 Hz)	1.0 bar(g) (50 / 60 Hz)	1.5 bar(g) (50 / 60 Hz)
Nominal motor rating	2.2 / 3.0 kW (50 / 60 Hz)	3.0 / 4.0 kW (50 / 60 Hz)	5.5 / 7.5 kW (50 / 60 Hz)
Nominal motor speed	1500 / 1800 min ⁻¹ (50 / 60 Hz)	1500 / 1800 min ⁻¹ (50 / 60 Hz)	1500 / 1800 min ⁻¹ (50 / 60 Hz)
Noise level (ISO 2151)	75 / 76 dB(A) (50 / 60 Hz)	76 / 77 dB(A) (50 / 60 Hz)	77 / 78 dB(A) (50 / 60 Hz)
Weight approx.	82 kg	94 kg	140 kg
Dimensions (L x W x H)	763 x 428 x 342 mm	798 x 428 x 342 mm	849 x 375 x 346 mm
Gas inlet / outlet	G 1¼" / G 1¼"	G 1¼" / G 1¼"	G 1¼" / G 1¼"

DO YOU WANT TO KNOW MORE?

Get in touch with us directly!
info@busch.ca or +1 800 363 6360



CONTACT FORM



CALL NOW