

SAMOS SB 0080-0200 D2

Side channel blowers

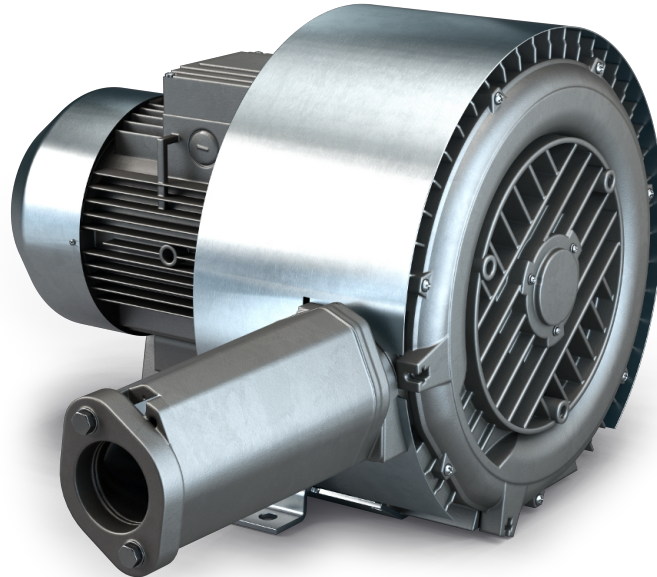

VACUUM SOLUTIONS



Reliable

Robust construction, effective air cooling, long lifetime, nearly maintenance-free, dry and contact-free operating principle, high differential pressures thanks to two compression stages

Flexible

Vacuum or overpressure operation, horizontal and vertical installation, various design options and ATEX-certified versions available

Quiet

Very low noise level, fully enclosed unit, internal silencers

Accessories

- Vacuum relief valves
- Pressure relief valves
- Additional silencers
- Thermal protection (bimetal switch or PTC-thermistor)

SAMOS SB 0080-0200 D2

Side channel blowers



VACUUM SOLUTIONS

Dimensional drawing

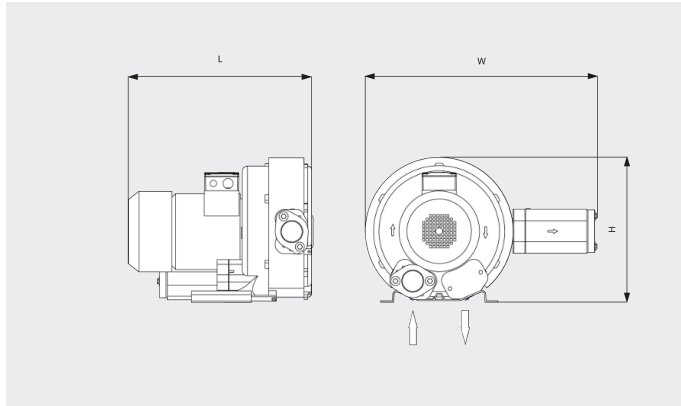

Pumping speed/Volume flow

Air at 20°C. Tolerance: ± 10%

— 50 Hz 60 Hz

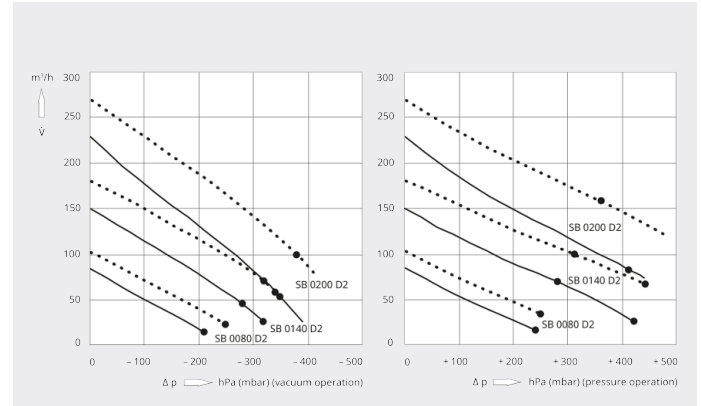

	SAMOS SB 0080 D2	SAMOS SB 0140 D2	SAMOS SB 0140 D2	SAMOS SB 0200 D2
Nominal pumping speed/volume flow	85 / 102 m³/h (50 / 60 Hz)	150 / 180 m³/h (50 / 60 Hz)	150 / 180 m³/h (50 / 60 Hz)	230 / 270 m³/h (50 / 60 Hz)
Max. differential pressure (vacuum version)	-210 / -250 hPa (mbar) (50 / 60 Hz)	-280 / -320 hPa (mbar) (50 / 60 Hz)	-320 / -350 hPa (mbar) (50 / 60 Hz)	-340 / -380 hPa (mbar) (50 / 60 Hz)
Max. differential pressure (overpressure version)	+240 / +250 hPa (mbar) (50 / 60 Hz)	+280 / +310 hPa (mbar) (50 / 60 Hz)	+420 / +440 hPa (mbar) (50 / 60 Hz)	+410 / +360 hPa (mbar) (50 / 60 Hz)
Nominal motor rating	0.7 / 0.8 kW (50 / 60 Hz)	1.6 / 2.0 kW (50 / 60 Hz)	2.2 / 2.5 kW (50 / 60 Hz)	3.0 / 3.4 kW (50 / 60 Hz)
Nominal motor speed	2850 / 3450 min ⁻¹ (50 / 60 Hz)	2850 / 3450 min ⁻¹ (50 / 60 Hz)	2850 / 3450 min ⁻¹ (50 / 60 Hz)	2850 / 3450 min ⁻¹ (50 / 60 Hz)
Noise level (ISO 3744)	55 / 61 dB(A) (50 / 60 Hz)	66 / 69 dB(A) (50 / 60 Hz)	66 / 69 dB(A) (50 / 60 Hz)	72 / 74 dB(A) (50 / 60 Hz)
Weight approx.	15 kg	25 kg	27 kg	40 kg
Dimensions (L x W x H)	316 x 475 x 270 mm	401 x 499 x 315 mm	401 x 499 x 315 mm	465 x 616 x 371 mm
Gas inlet / outlet	G 1¼" / G 1¼"	G 1¼" / G 1¼"	G 1¼" / G 1¼"	G 2" / G 2"

DO YOU WANT TO KNOW MORE?

Get in touch with us directly!
info@busch.ca or +1 800 363 6360



CONTACT FORM



CALL NOW