

R5 RB/RC 0021 C

Oil-lubricated rotary vane vacuum pumps



VACUUM SOLUTIONS



Compact

Reduced height and weight, ideal for installations in confined spaces

Reliable

Robust construction, highly durable fiber-reinforced epoxy resin vanes, proven rotary vane technology, long service life

Flexible

Various design options available, easy adaption to individual customer requirements and processes

Accessories

- Gas-ballast valve
- Filter pressure gauge
- Vacuum pump oils for all applications
- Various inlet filters
- Oil level switch
- Vacuum regulating unit

R5 RB/RC 0021 C

Oil-lubricated rotary vane vacuum pumps



VACUUM SOLUTIONS

Dimensional drawing

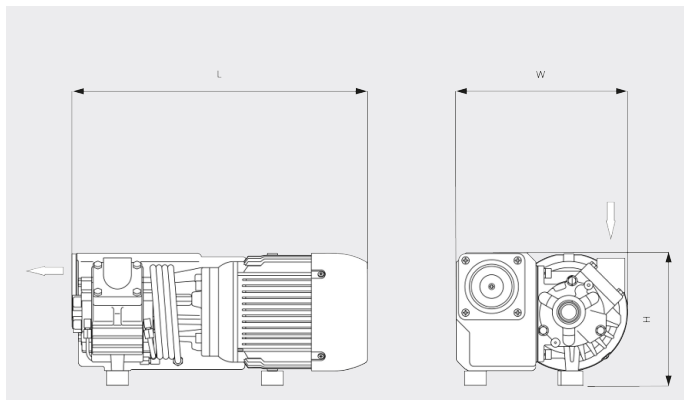

Pumping speed

Air at 20°C. Tolerance: ± 10%

— 50 Hz 60 Hz

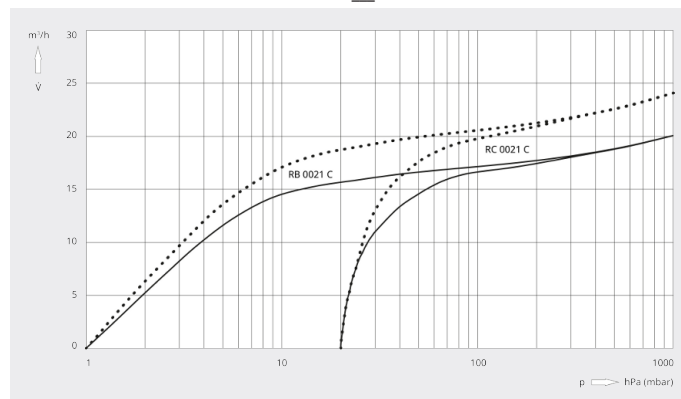

	R5 RB 0021 C	R5 RC 0021 C
Nominal pumping speed	20 / 24 m³/h (50 / 60 Hz)	20 / 24 m³/h (50 / 60 Hz)
Ultimate pressure	1.0 hPa (mbar) (50 / 60 Hz)	20.0 hPa (mbar) (50 / 60 Hz)
Nominal motor rating	0.75 / 0.9 kW (50 / 60 Hz)	0.75 / 0.9 kW (50 / 60 Hz)
Nominal motor speed	3000 / 3600 min ⁻¹ (50 / 60 Hz)	3000 / 3600 min ⁻¹ (50 / 60 Hz)
Noise level (ISO 2151)	66 / 72 dB(A) (50 / 60 Hz)	66 / 72 dB(A) (50 / 60 Hz)
Oil capacity	0.45 l	0.45 l
Weight approx.	20 kg	20 kg
Dimensions (L x W x H)	401 x 229 x 180 mm	401 x 229 x 180 mm
Gas inlet	G ½"	G ½"

DO YOU WANT TO KNOW MORE?

Get in touch with us directly!
info@busch.ca or +1 800 363 6360



CONTACT FORM



CALL NOW