

R5 KB 0020-0040 D/F

Oil-lubricated rotary vane vacuum pumps



VACUUM SOLUTIONS



Compact

Direct-drive construction, reduced height and weight, ideal for installation in vacuum packaging machines

Reliable

Robust construction, highly durable vanes, proven rotary vane technology, long service life

Flexible

Various design options available, easy adaption to individual customer requirements and processes

Accessories

- Gas-ballast valve
- Filter pressure gauge
- Vacuum pump oils for all applications
- Various inlet filters
- Oil level switch
- Vacuum regulating unit

R5 KB 0020-0040 D/F

Oil-lubricated rotary vane vacuum pumps



Dimensional drawing

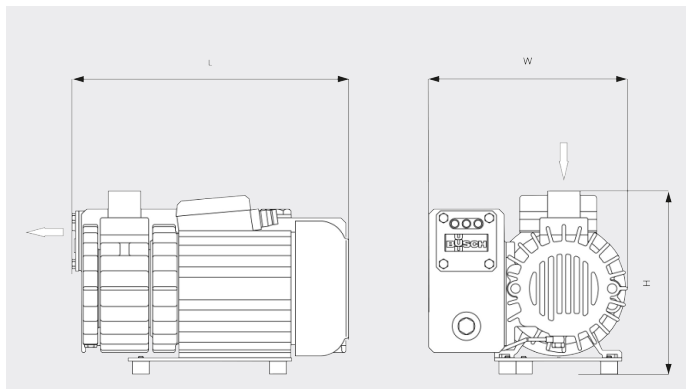

Pumping speed

Air at 20°C. Tolerance: ± 10%

— 50 Hz 60 Hz

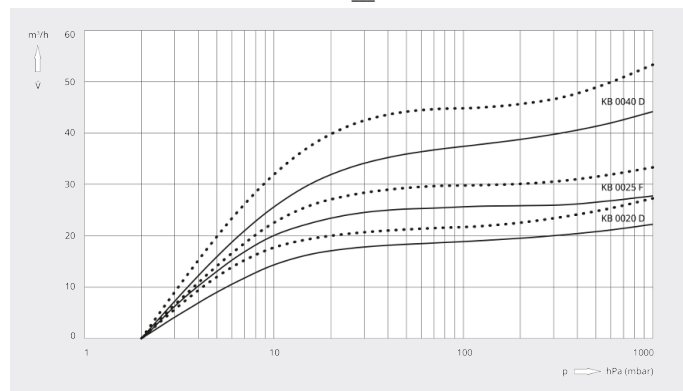

	R5 KB 0020 D	R5 KB 0025 F	R5 KB 0040 D
Nominal pumping speed	20 / 24 m³/h (50 / 60 Hz)	25 / 30 m³/h (50 / 60 Hz)	40 / 48 m³/h (50 / 60 Hz)
Ultimate pressure	2.0 hPa (mbar) (50 / 60 Hz)	2.0 hPa (mbar) (50 / 60 Hz)	2.0 hPa (mbar) (50 / 60 Hz)
Nominal motor rating	0.75 kW (50 / 60 Hz)	0.9 / 1.1 kW (50 / 60 Hz)	1.5 kW (50 / 60 Hz)
Nominal motor speed	3000 / 3600 min ⁻¹ (50 / 60 Hz)	3000 / 3600 min ⁻¹ (50 / 60 Hz)	3000 / 3600 min ⁻¹ (50 / 60 Hz)
Noise level (ISO 2151)	67 / 70 dB(A) (50 / 60 Hz)	71 / 73 dB(A) (50 / 60 Hz)	71 / 75 dB(A) (50 / 60 Hz)
Oil capacity	0.45 l	0.45 l	0.8 l
Weight approx.	19 kg	20 kg	29 kg
Dimensions (L x W x H)	323 x 231 x 211 mm	347 x 250 x 229 mm	432 x 256 x 238 mm
Gas inlet / outlet	G ¾" / -	G ¾" / -	G 1¼" G 1¼"

DO YOU WANT TO KNOW MORE?

Get in touch with us directly!
info@busch.ca or +1 800 363 6360



CONTACT FORM



CALL NOW