

PUMA WP 0250/0500 D2/D4

Vacuum boosters



VACUUM SOLUTIONS



Reliable

Solid lobe design, robust construction made of GGG40 material

High performance

Excellent volumetric efficiency, increases the performance of a vacuum system by up to a factor of ten, specially designed for rough and medium vacuum applications

Flexible

Can be flanged directly on the system at any position, boosts the performance of all types of backing pumps

PUMA WP 0250/0500 D2/D4

Vacuum boosters



VACUUM SOLUTIONS

Dimensional drawing

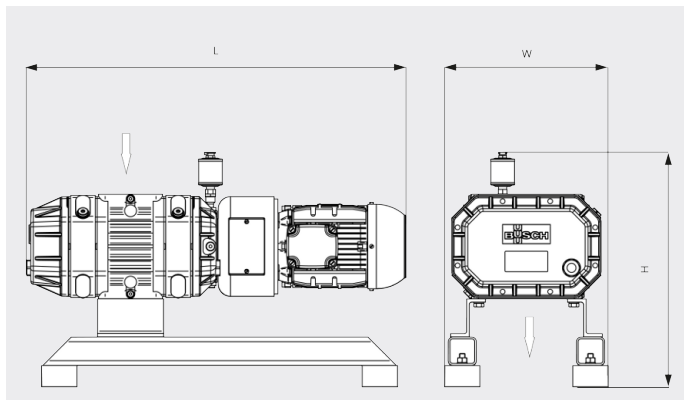

Pumping speed

Air at 20°C. Tolerance: ± 10%

— 50 Hz 60 Hz

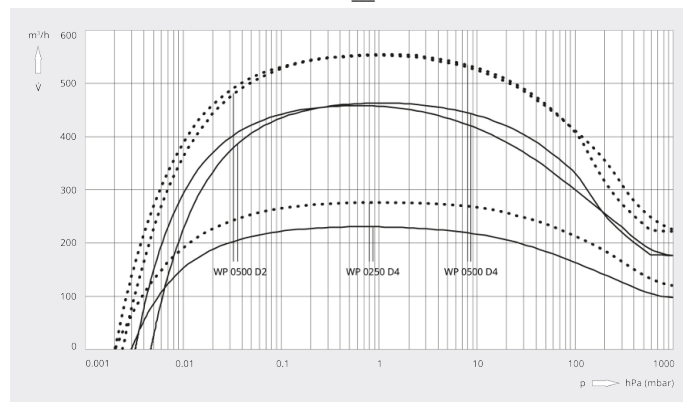

	PUMA WP 0250 D4	PUMA WP 0500 D2	PUMA WP 0500 D4
Pumping speed	260 / 310 m³/h (50 / 60 Hz)	520 / 620 m³/h (50 / 60 Hz)	520 / 620 m³/h (50 / 60 Hz)
Pumping speed	231 / 277 m³/h (50 / 60 Hz)	463 / 554 m³/h (50 / 60 Hz)	458 / 552 m³/h (50 / 60 Hz)
Max. differential pressure	80 hPa (mbar) (50 / 60 Hz)	50 hPa (mbar) (50 / 60 Hz)	80 hPa (mbar) (50 / 60 Hz)
Nominal motor rating	1.1 / 1.5 kW (50 / 60 Hz)	2.2 / 3.0 kW (50 / 60 Hz)	1.8 / 2.4 kW (50 / 60 Hz)
Nominal motor speed	1500 / 1800 min ⁻¹ (50 / 60 Hz)	3000 / 3600 min ⁻¹ (50 / 60 Hz)	1500 / 1800 min ⁻¹ (50 / 60 Hz)
Weight approx.	150 kg	150 kg	200 kg
Dimensions (L x W x H)	792 x 345 x 494 mm	813 x 345 x 494 mm	971 x 345 x 494 mm
Gas inlet / outlet	DN 63 ISO / DN 63 ISO	DN 63 ISO / DN 63 ISO	DN 160 ISO / DN 160 ISO

DO YOU WANT TO KNOW MORE?

Get in touch with us directly!
info@busch.ca or +1 800 363 6360



CONTACT FORM



CALL NOW