

# HUCKEPACK HO 0429-0441 F

Once-through oil-lubricated rotary vane vacuum pumps



VACUUM SOLUTIONS



## Robust

Reliable operation, proven performance, high vapor and particle tolerance, resistant to sticky and very aggressive substances, fresh oil lubrication for outstanding running qualities, highly resistant carbon fiber composite vanes

## Flexible

Specially designed for particularly complex processes, for example in the chemical, pharmaceutical and special food packaging industries, easy adaption to individual customer requirements and processes, ATEX-version available

## Easy servicing

Minimal maintenance, no special tools necessary, modular design for rapid exchange of stages

### Accessories

- Oil mist separator
- Various inlet filters
- Oil and flushing tank in reinforced plastic or stainless-steel material
- Flushing device, manual and automatic
- Monitoring and safety devices
- Level switch
- Temperature switch
- Pressure switch
- Proximity switch
- Temperature control valve
- Different choices of vanes
- Large choice of lubricants and flushing liquids
- Radiator cooling system
- Duosec safety knock-out 3-phase separator
- Direct or star / delta switching devices
- Exhaust silencer
- Gas-ballast valve
- Silencer
- ATEX certification

# HUCKEPACK HO 0429-0441 F

Once-through oil-lubricated rotary vane vacuum pumps



VACUUM SOLUTIONS

Dimensional drawing

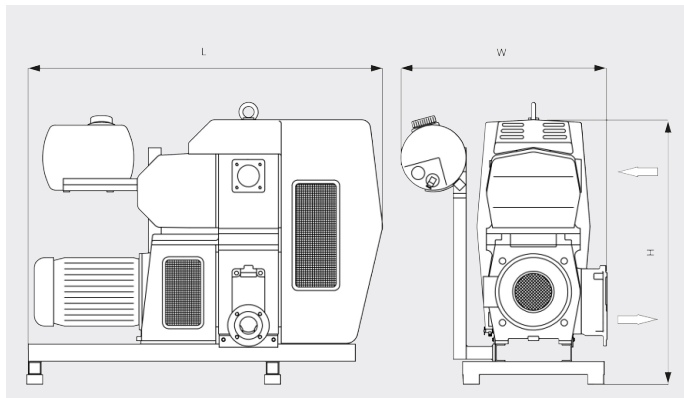

Pumping speed

Air at 20°C. Tolerance: ± 10%

— 50 Hz ..... 60 Hz

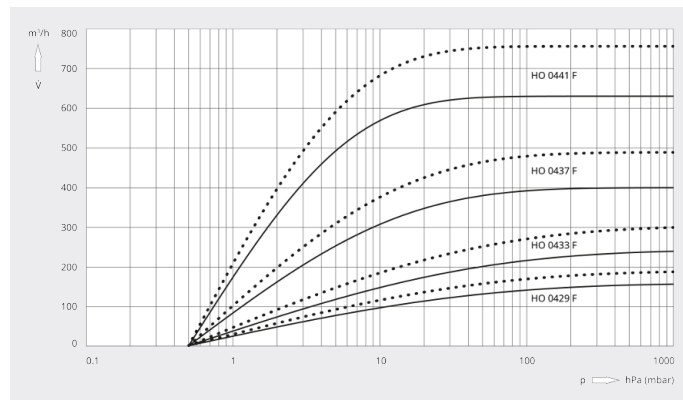

	HUCKEPACK HO 0429 F	HUCKEPACK HO 0433 F	HUCKEPACK HO 0437 F	HUCKEPACK HO 0441 F
<b>Nominal pumping speed</b>	160 / 190 m³/h (50 / 60 Hz)	250 / 300 m³/h (50 / 60 Hz)	400 / 480 m³/h (50 / 60 Hz)	630 / 760 m³/h (50 / 60 Hz)
<b>Ultimate pressure</b>	0.5 hPa (mbar) (50 / 60 Hz)	0.5 hPa (mbar) (50 / 60 Hz)	0.5 hPa (mbar) (50 / 60 Hz)	0.5 hPa (mbar) (50 / 60 Hz)
<b>Nominal motor rating</b>	5.5 / 9.2 kW (50 / 60 Hz)	7.5 / 9.2 kW (50 / 60 Hz)	11.0 / 15.0 kW (50 / 60 Hz)	15.0 / 18.5 kW (50 / 60 Hz)
<b>Nominal motor speed</b>	1500 / 1800 min <sup>-1</sup> (50 / 60 Hz)	1500 / 1800 min <sup>-1</sup> (50 / 60 Hz)	1000 / 1200 min <sup>-1</sup> (50 / 60 Hz)	1000 / 1200 min <sup>-1</sup> (50 / 60 Hz)
<b>Noise level (ISO 2151)</b>	72 dB(A) (50 / 60 Hz)	73 dB(A) (50 / 60 Hz)	73 dB(A) (50 / 60 Hz)	74 dB(A) (50 / 60 Hz)
<b>Weight approx.</b>	385 kg	440 kg	930 kg	1000 kg
<b>Dimensions (L x W x H)</b>	1320 x 740 x 1160 mm	1320 x 740 x 1160 mm	1640 x 950 x 1240 mm	1640 x 950 x 1240 mm
<b>Gas inlet / outlet</b>	DN 80 / DN 50	DN 80 / DN 50	DN 80 / DN 80	DN 80 / DN 80

## DO YOU WANT TO KNOW MORE?

Get in touch with us directly!  
[info@busch.ca](mailto:info@busch.ca) or +1 800 363 6360



CONTACT FORM



CALL NOW