

DOLPHIN VL 0100-0270 A

Total Recirculation

Liquid ring vacuum pump units



VACUUM SOLUTIONS

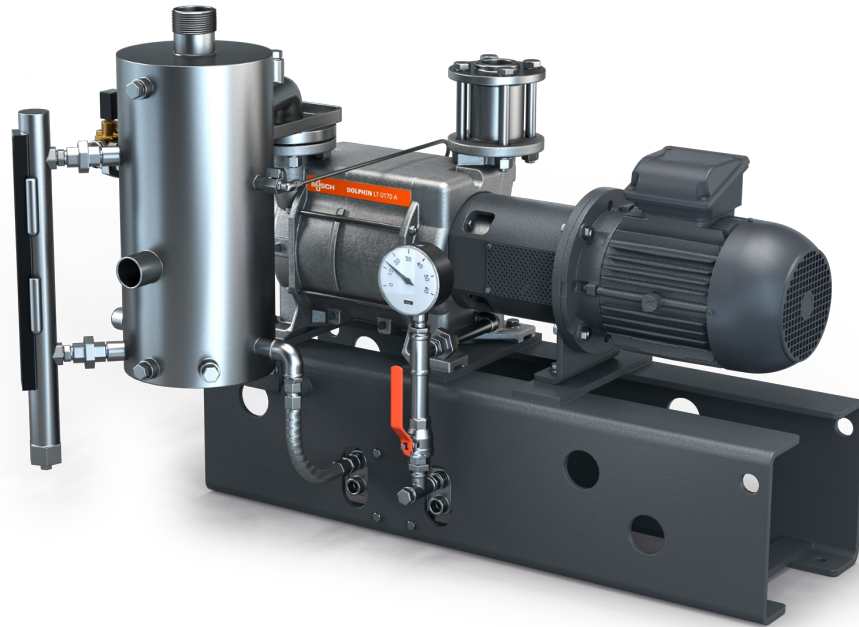

Robust

Proven technology, reliable operation, corrosion-free stainless steel impeller, extremely high vapor and particle tolerance, choice of cast iron (EN-GJL-200) or 316 grade stainless steel material housings, ATEX-certified version available (Cat. 1 (i/o) IIC, T4)

All-in-One

Unit with base frame, operating fluid separator, heat exchanger, control system, including inlet check valve, fresh liquid supply kit, level indicator with switches, temperature and pressure indicators and cavitation protection

Efficient

Full recirculation of operating fluid, low operating fluid consumption, recovery of condensed vapors and process gases, isolation of cooling liquid from operating fluid, operating fluids other than water possible

DOLPHIN VL 0100-0270 A Total Recirculation

Liquid ring vacuum pump units



VACUUM SOLUTIONS

Dimensional drawing

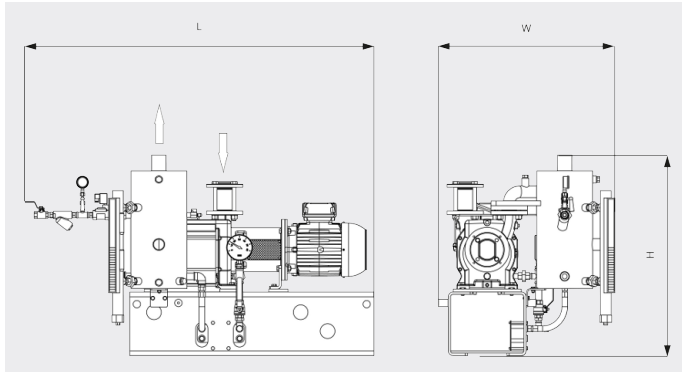

Dimensional drawing

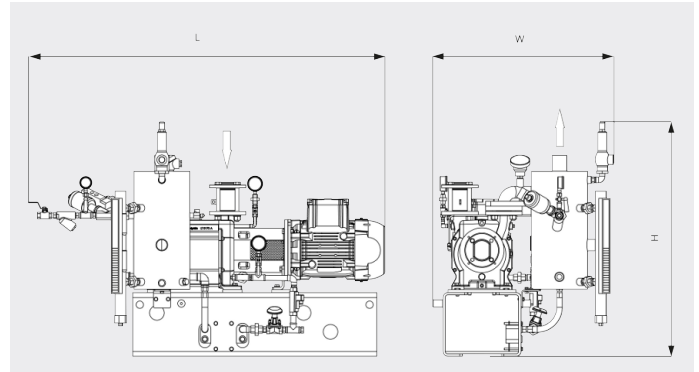

	DOLPHIN VL 0100 A Total Recirculation	DOLPHIN VL 0180 A Total Recirculation	DOLPHIN VL 0270 A Total Recirculation
Nominal pumping speed	82 / 98 m ³ /h (50 / 60 Hz)	144 / 180 m ³ /h (50 / 60 Hz)	220 / 267 m ³ /h (50 / 60 Hz)
Ultimate pressure	130 hPa (mbar) (50 / 60 Hz)	130 hPa (mbar) (50 / 60 Hz)	130 hPa (mbar) (50 / 60 Hz)
Nominal motor rating	2.2 / 3.0 kW (50 / 60 Hz)	4.0 / 5.5 kW (50 / 60 Hz)	5.5 / 7.5 kW (50 / 60 Hz)
Weight approx.	206 / 231 kg (Safe / ATEX)	214 / 256 kg (Safe / ATEX)	256 / 293 kg (Safe / ATEX)
Dimensions (L x W x H)	983 x 730 x 819 / 1020 x 737 960 mm (Safe / ATEX)	1033 x 730 x 819 / 1090 x 737 x 960 mm (Safe / ATEX)	1136 x 730 x 819 / 1208 x 737 x 960 mm (Safe / ATEX)
Gas inlet / outlet	G 1½" / R 2"	G 1½" / R 2"	G 1½" / R 2"

DO YOU WANT TO KNOW MORE?

Get in touch with us directly!
info@busch.ca or +1 800 363 6360



CONTACT FORM



CALL NOW