

DOLPHIN LX 0260-0430 C

Liquid ring vacuum pumps



VACUUM SOLUTIONS



Robust

Proven technology, reliable operation, extremely high particle and vapor tolerance, corrosion-free stainless steel impeller

Compact

Directly flanged motor, no base frame required

Flexible

Choice of cast iron (EN-GJL-200) or 316 grade stainless steel material housings, ATEX-certified version available (Cat. 2 (i) IIB, T4), operating fluids other than water possible

DOLPHIN LX 0260-0430 C

Liquid ring vacuum pumps



VACUUM SOLUTIONS

Dimensional drawing

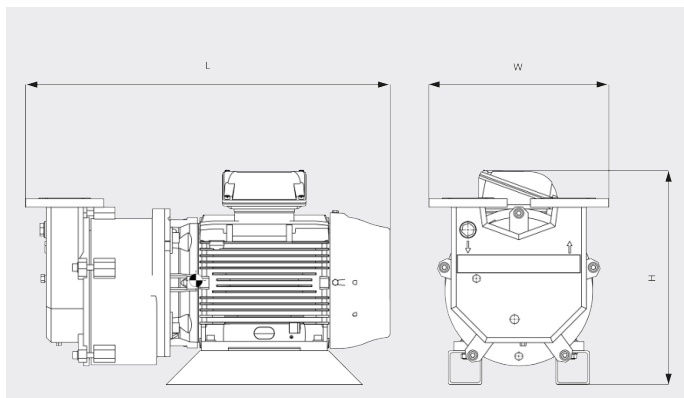

Pumping speed

Dry air at 20 °C. Operating fluid water 15°C. Tolerance: - 10%, in accordance with HEI and Pneurop 6612

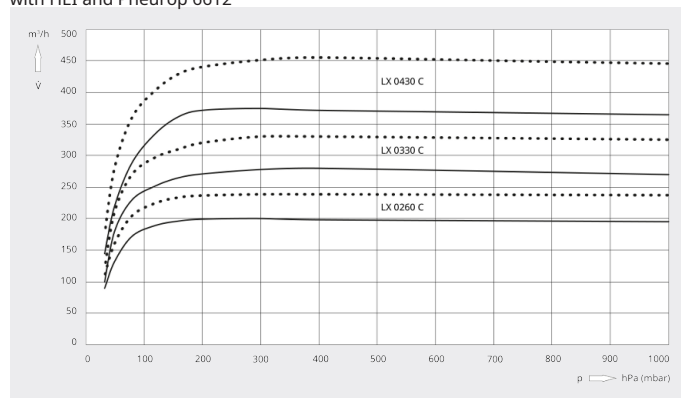

	DOLPHIN LX 0260 C	DOLPHIN LX 0330 C	DOLPHIN LX 0430 C
Nominal pumping speed	200 / 239 m ³ /h (50 / 60 Hz)	280 / 330 m ³ /h (50 / 60 Hz)	375 / 455 m ³ /h (50 / 60 Hz)
Ultimate pressure	33 hPa (mbar) (50 / 60 Hz)	33 hPa (mbar) (50 / 60 Hz)	33 hPa (mbar) (50 / 60 Hz)
Nominal motor rating	5.5 / 7.5 kW (50 / 60 Hz)	7.5 / 11.0 kW (50 / 60 Hz)	11.0 / 15.0 kW (50 / 60 Hz)
Nominal motor speed	1450 / 1750 min ⁻¹ (50 / 60 Hz)	1450 / 1750 min ⁻¹ (50 / 60 Hz)	1450 / 1750 min ⁻¹ (50 / 60 Hz)
Noise level (ISO 2151)	72 dB(A) (50 / 60 Hz)	72 dB(A) (50 / 60 Hz)	72 dB(A) (50 / 60 Hz)
Weight approx.	135 / 145 kg (50 / 60 Hz)	147 / 198 kg (50 / 60 Hz)	227 / 247 kg (50 / 60 Hz)
Dimensions (L x W x H)	635 x 365 x 402 mm	706 x 365 x 402 mm	818 x 425 x 506 mm
Gas inlet / outlet	DN 50 PN16 / DN 50 PN16	DN 50 PN16 / DN 50 PN16	DN 65 PN16 / DN 65 PN16

DO YOU WANT TO KNOW MORE?

Get in touch with us directly!
info@busch.ca or +1 800 363 6360



CONTACT FORM



CALL NOW