

DOLPHIN LG 1910/2680 A

Liquid ring vacuum pumps



VACUUM SOLUTIONS



Robust

Proven technology, reliable operation, extremely high vapor and particle tolerance, specially designed for challenging environments like mining, power plants, sugar production, pulp and paper industry, steel production etc.

High performance

High-capacity, high pumping speeds

Flexible

Modular design, choice of cast iron (EN-GJL-200) housing with ductile cast iron impeller or all 316 grade corrosion-free stainless steel material, operating fluids other than water possible, operation as compressor possible

Accessories

- Motorized pumpsets, with gearbox or V-belt drive system, mounted on sturdy steel base frames
- Partial or total recirculation systems
- Cavitation protection
- Gas ejector
- Non-return valves
- Vacuum relief valves

DOLPHIN LG 1910/2680 A

Liquid ring vacuum pumps



VACUUM SOLUTIONS

Dimensional drawing

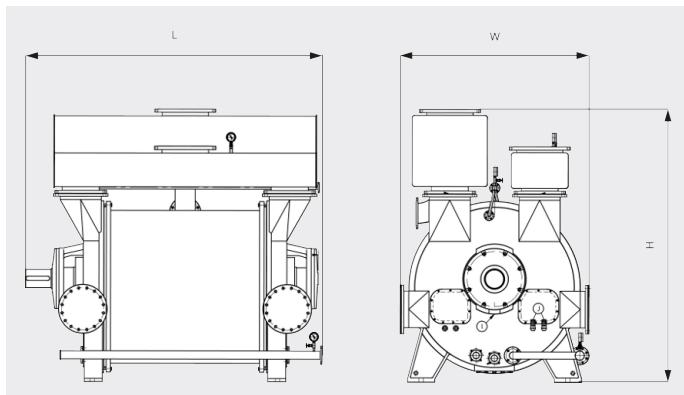

Pumping speed

Air at 20°C. Tolerance: ± 10%

— 50 Hz 60 Hz

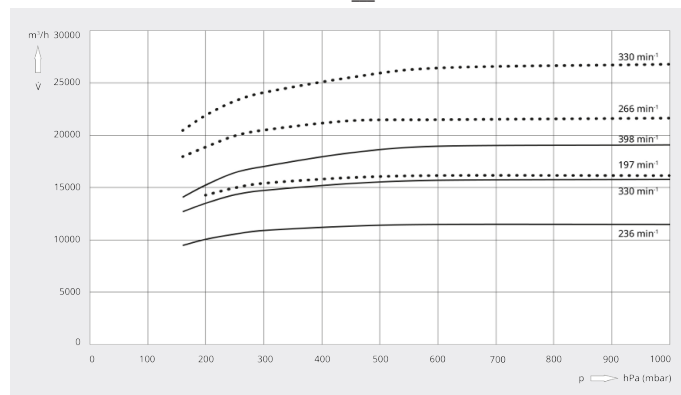

	DOLPHIN LG 1910 A	DOLPHIN LG 2680 A
Nominal pumping speed	11550 – 19100 m ³ /h	16160 – 26800 m ³ /h
Ultimate pressure	160 hPa (mbar)	160 hPa (mbar)
Nominal motor rating	220 – 500 kW	355 – 650 kW
Nominal motor speed	236 – 398 min ⁻¹	197 – 330 min ⁻¹
Noise level (ISO 2151)	< 85 dB(A)	< 85 dB(A)
Weight approx.	8930 kg	12750 kg
Dimensions (L x W x H)	2732 x 1785 x 2560 mm	3191 x 2065 x 2965 mm
Gas inlet / outlet	DN 400 PN 10 / DN 400 PN 10	DN 500 PN 10 / DN 500 PN 10

DO YOU WANT TO KNOW MORE?

Get in touch with us directly!
info@busch.ca or +1 800 363 6360



CONTACT FORM



CALL NOW