

# COBRA DS 8162/8163 B/F

Dry screw vacuum pumps



VACUUM SOLUTIONS



## High performance

Advanced screw design, excellent running qualities, integrated vacuum booster, perfectly suited for high-capacity load lock and coating processes

## Efficient

Low cost of ownership, minimal maintenance, long service intervals, high uptime, efficient water cooling, high solvent throughput

## Compact

Fit-in-place design, directly mounted canned motor, backing pump and vacuum booster combined on a compact base frame, modular design

# COBRA DS 8162/8163 B/F

Dry screw vacuum pumps



VACUUM SOLUTIONS

Dimensional drawing

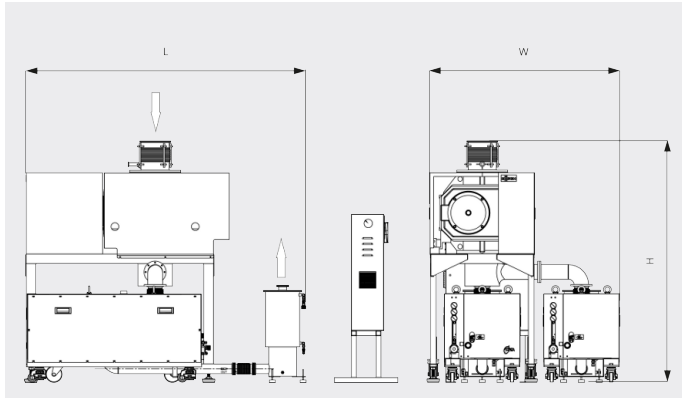

Pumping speed

Air at 20°C. Tolerance: ± 10%

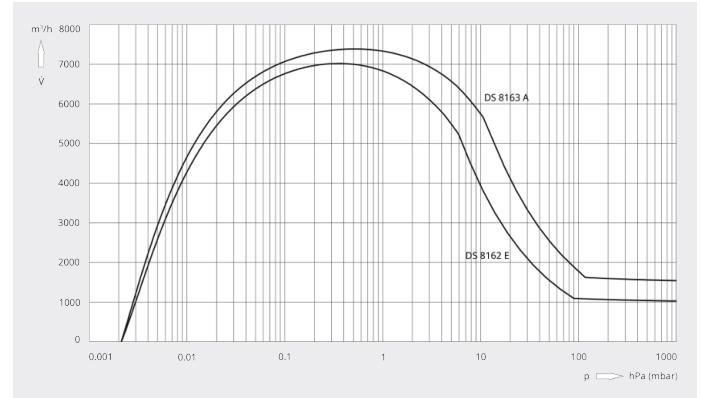

	COBRA DS 8162 F	COBRA DS 8163 B
Nominal pumping speed	7000 m <sup>3</sup> /h	7385 m <sup>3</sup> /h
Ultimate pressure	0.001 hPa (mbar)	0.001 hPa (mbar)
Nominal motor rating backing pump	2 · 15 kW	3 · 15 kW
Nominal motor rating vacuum booster	20 kW	20 kW
Power consumption at ultimate pressure / idle mode	21 / 19 kW	21 / 19 kW
Nominal motor speed backing pump	3600 min <sup>-1</sup>	3600 min <sup>-1</sup>
Nominal motor speed vacuum booster	3600 min <sup>-1</sup>	3600 min <sup>-1</sup>
Noise level (ISO 2151)	< 78 dB(A)	< 78 dB(A)
Water consumption	22 l/min	31 l/min
Nitrogen consumption	2 · (0 – 200) l/min	3 · (0 – 200) l/min
Weight approx.	2500 kg	3320 kg
Dimensions (L x W x H)	1604 x 1470 x 1860 mm	1604 x 2114 x 1860 mm
Gas inlet / outlet	DN 200 / 2 · DN 63	DN 200 / 3 · DN 63

DO YOU WANT TO KNOW MORE?

Get in touch with us directly!  
[info@busch.ca](mailto:info@busch.ca) or +1 800 363 6360



CONTACT FORM



CALL NOW