

# R5 KB 0010/0016 E

Oil-lubricated rotary vane vacuum pumps



## Compact

Direct-drive construction, reduced height and weight, ideal for installation in vacuum packaging machines

## Reliable

Robust construction, highly durable vanes, proven rotary vane technology, long service life

## Flexible

Various design options available, easy adaption to individual customer requirements and processes

### Accessories

- Gas-ballast valve
- Filter pressure gauge
- Vacuum pump oils for all applications
- Various inlet filters
- Oil level switch
- Vacuum regulating unit

# R5 KB 0010/0016 E

Oil-lubricated rotary vane vacuum pumps



VACUUM SOLUTIONS

Dimensional drawing

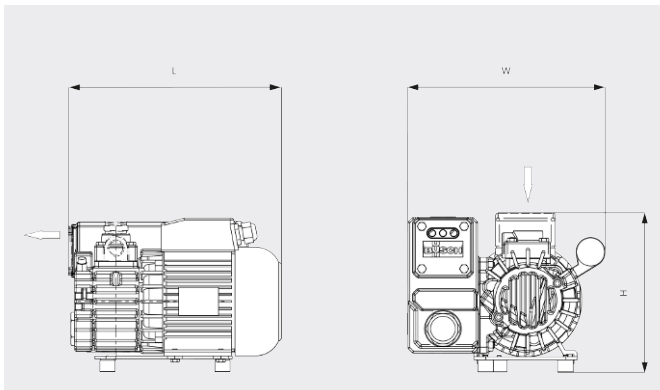

Pumping speed

Air at 20°C. Tolerance: ± 10%

— 50 Hz ..... 60 Hz

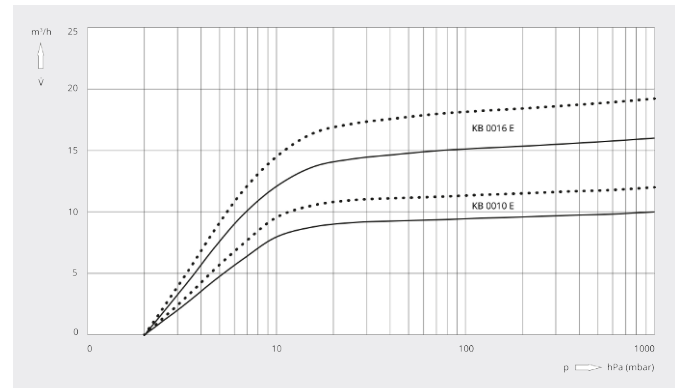

	R5 KB 0010 E	R5 KB 0016 E
<b>Nominal pumping speed</b>	10 / 12 m <sup>3</sup> /h (50 / 60 Hz)	16 / 19 m <sup>3</sup> /h (50 / 60 Hz)
<b>Ultimate pressure</b>	2.0 hPa (mbar) (50 / 60 Hz)	2.0 hPa (mbar) (50 / 60 Hz)
<b>Nominal motor rating</b>	0.37 kW (50 / 60 Hz)	0.55 kW (50 / 60 Hz)
<b>Nominal motor speed</b>	3000 / 3600 min <sup>-1</sup> (50 / 60 Hz)	3000 / 3600 min <sup>-1</sup> (50 / 60 Hz)
<b>Noise level (ISO 2151)</b>	63 / 67 dB(A) (50 / 60 Hz)	64 / 68 dB(A) (50 / 60 Hz)
<b>Oil capacity</b>	0.3 l	0.3 l
<b>Weight approx.</b>	16 kg	18 kg
<b>Dimensions (L x W x H)</b>	271 x 218 x 201 mm	301 x 217 x 201 mm
<b>Gas inlet</b>	G 3/4"	G 3/4"

DO YOU WANT TO KNOW MORE?

Get in touch with us directly!



CONTACT FORM