

Installation and Operating Instructions

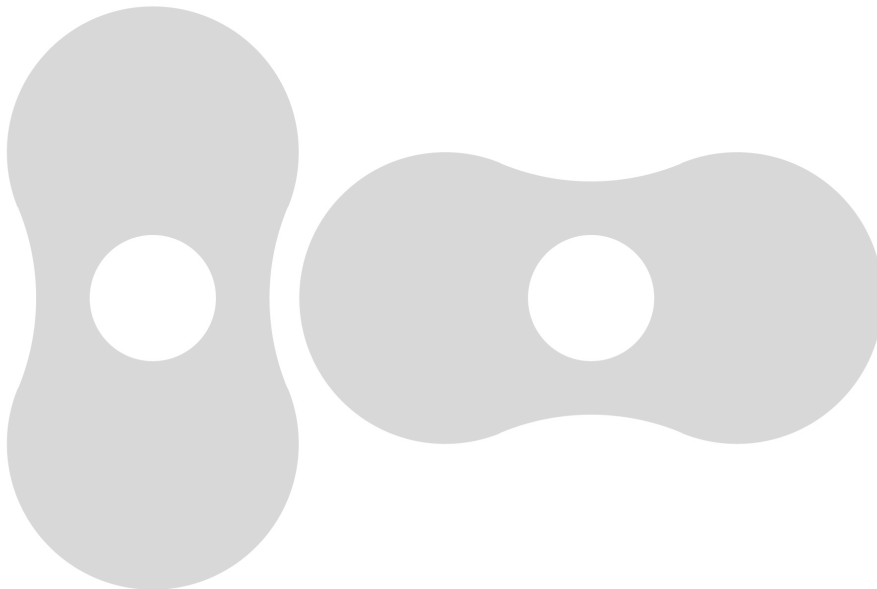

Vacuum pumps WPA 040/ 055/
075/ 080/ 095 A



Table of Contents

Introduction	2
Product description	3
Use	3
Principle of operation	3
Cooling	3
On/Off switch	3
Safety	3
Intended use	3
Safety notes	3
Sound Emissions	4
Transport	4
Transport in Packaging	4
Transport without packaging	4
Storage	4
Short-term Storage	4
Removal of the pump	4
Conservation	4
Commissioning after conservation	5
Installation and Commissioning	5
Installation Prerequisites	5
Local installation	5
Suction Connection	5
Discharge connection	6
Drive/ Coupling	6
Coupling alignment	6
Electrical connection/ Controls	6
Installation	7
Fitting	7
Electrical connection	7
Operation with frequency converter	7
With pole-changing motor	7
Connecting lines/ piping	7
Filling up with Oil	8
Saving the Operating Parameters	8
Water-cooled seal ring housing	8
Preconditions to water-cooling:	8
Water quantities:	9
Recommendation:	9
Recommendations on operation	9
Application	9
New start after shut-down under working pressure	
(high end pressure):	9
Heatable Roots vacuum pump WPA	10
Limitations of use	10
Maintenance	10
Maintenance Schedule	10
Weekly	10
Monthly:	10
After the first 500 operating hours	10
After each 4000 operating hours, latest every year	10
Every 20000 operating hours, at the latest after 3 Years	10
Checking the oil	10
Checking the oil level at the gears and bearing housings	10
Oil level with mineral oil:	10
Oil level with Fomblin oil:	11
Checking the oil level in the seal housing	11
Topping up with oil	11
Checking the colour of the oil	11
Life span of the oil at the gears and the bearings	11
Life span of the oil in the seal housing	11
Oil Change	11
Draining used oil from the gears and the bearings	11
Draining used oil from the seal housing	11
Filling in fresh oil for the gears and the bearings	12
Filling in fresh oil for the seal housing	12
Overhaul	12
Removal from Service	12
Temporary preservation	12
Recommissioning	12
Dismantling and Disposal	13
Exploded view	14
Full service kit	16
Oil	17

Oil for the gears and bearings	17
Oil for seal housing	17
Technical Data	18
Troubleshooting	19
EU-Declaration of Conformity	21
UK-Declaration of Conformity	22

Introduction

Congratulations on your purchase of the Busch vacuum pump/ compressor/ vacuum and pressure pump/ blower. With careful observation of the field's requirements, innovation and continuous development, Busch delivers modern vacuum and pressure solutions worldwide.

These operating instructions contain information on

- product description,
- security,
- transport,
- storage,
- installation and commissioning
- maintenance,
- overhaul,
- troubleshooting

of the vacuum pump.

For the purpose of these instructions, "handling" the vacuum system means the transport, storage, installation, commissioning, influence on operating conditions, maintenance, troubleshooting and overhaul of the vacuum system.

Prior to handling the vacuum system, these operating instructions must be read and understood. If anything remains to be clarified please contact your Busch representative!

Keep these operating instructions and, if applicable, other relevant operating instructions available and accessible on site.

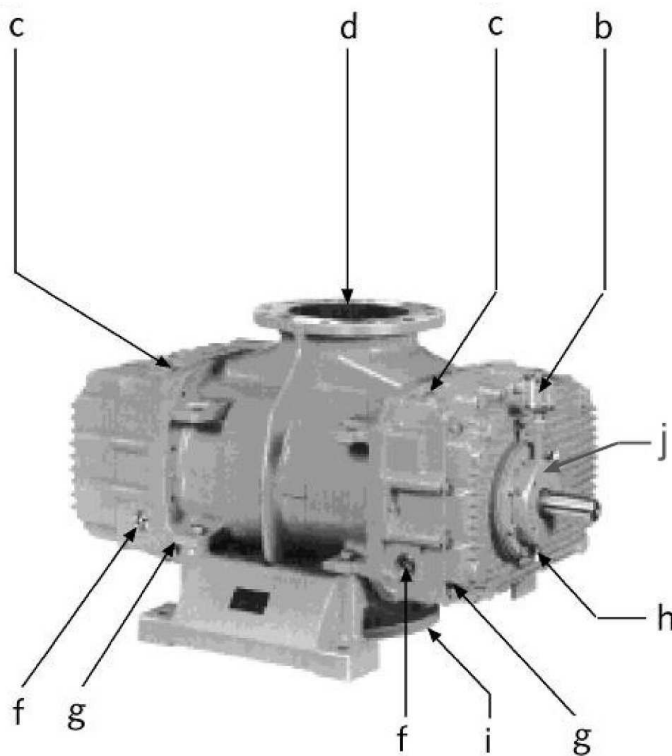

- b Drop oiler
- c Oil filler plug
- d Inlet
- f Oil sight glass
- g Oil drain plug (under the pump)
- h Drain plug, seal ring housing
- i Outlet
- j Vent plug, seal ring housing

Product description

Use

The vacuum pump is intended for

- the suction of
- air and other dry, non-aggressive, non-toxic and non-explosive gases.

The Roots vacuum pumps are usually used as backing pumps in conjunction with other types of vacuum pumps in vacuum systems.

Conveying media with a higher density than air leads to an increased thermal and mechanical load on the vacuum pump and is permissible only after consultation with a Busch company.

Max. allowed temperature of the drawn gases:

See "Oil, Ambient temperature range"

Make sure that the oil level of both housings is in the upper third of the oil sight glasses (Fomblin oil) when the vacuum pump is at standstill.

Make sure that the oil level in both housings is in the middle of the oil sight glasses (mineral oil) after the vacuum pump is at standstill.

Make sure that the oil filling level of the drop oiler (b) is in the middle of the oil sight glass.

The vacuum pump is intended for installation in a potentially non-explosive environment (ATEX).

Max. permissible number of startings per hour: 6.

The vacuum pump is thermally suitable for continuous operation.

The vacuum pump is capable of holding end pressure.

Principle of operation

The Roots vacuum pumps operate according to the approved principle of the Roots type machine. Operation is both simple and effective. Two rotors with identical profiles rotate in opposite directions within a casing. As they rotate, gas is drawn into the space between each rotor and the casing where it is trapped and pushed out at the discharge through the rotation of the lobes. This action is repeated twice for each

revolution of each rotor and therefore four times for each revolution of the drive shaft. There is no mechanical contact between rotors and cylinder, therefore no oil lubrication in the process chamber is required.

Cooling

All versions are air-cooled.

On/Off switch

The vacuum pump comes without on/off switch. The control of the vacuum pump must be provided in the course of the installation.

Safety

Intended use

DEFINITION: For the purpose of these instructions, "handling" the vacuum pump means the transport, storage, installation, commissioning, influence on operating conditions, maintenance, troubleshooting and overhaul of the vacuum pump.

The vacuum pump is intended for industrial use. It must be handled by qualified personnel only.

The different applications for use and operational limits of the vacuum pump as laid out in the "Product Description" and the "Installation Prerequisites" of the vacuum pump must be observed both by the manufacturer of the machinery into which the vacuum pump is to be incorporated and by the end user.

The maintenance instructions must be observed.

Non-observance of the technical application limits and safety regulations releases Ateliers Busch from warranty and liability regarding replacement for consequential damages. The same applies for defects caused by inspections carried out improperly or outside the given maintenance intervals.

Prior to handling the vacuum pump these operating instructions must be read and understood. If anything remains to be clarified please contact your Busch representative!

Safety notes

The vacuum pump has been designed and manufactured in accordance with the latest technical and safety standards. Nevertheless, residual

risks may remain. These operating instructions and the pump itself inform about potential hazards where appropriate. Safety instructions can be detected through the keywords, DANGER, WARNING and CAUTION as follows:



DANGER

Disregard of this safety instruction will always lead to accidents with fatal or serious injuries.



WARNING

Disregard of this safety instruction may lead to accidents with fatal or serious injuries.



CAUTION

Disregard of this safety instruction may lead to accidents with minor injuries or property damage.

Sound Emissions

Refer to the table "Technical Properties" for the permissible sound levels in free field conditions according to EN ISO 2151.



CAUTION

The vacuum pump emits sounds of high intensity.

Risk of hearing damage.

Users spending a longer period of time in the vicinity of a non-insulated vacuum pump must wear suitable hearing protection.

Transport

Roots vacuum pumps undergo a rigorous operating test in the factory and are packed carefully to avoid transport damage. The inlet and outlet flange are sealed with plugs so that no dirt can enter the pump during transport. These covers must be removed before connecting up the pump.

Please check packaging for transport damage on delivery.

The pump can be lifted from its packaging using the lifting brackets on the pump and a suitable lifting gear or by using belts.

The packaging materials must be disposed of in accordance with applicable environmental protection regulations, or re-used. These operating instructions are part of the delivery packaging consignment.

Pumps are generally shipped without oil.

Operating the vacuum pump without oil will destroy the pump!

Transport in Packaging

When packed onto a pallet, the vacuum pump can be moved with suitable transport equipment.

Transport without packaging



CAUTION

Please check out the weight of the vacuum pump before lifting it up (see "Technical Data").

Use adequate lifting gear for this.

In case the vacuum pump is bolted to a pallet or a base plate :

- ◆ Remove the fixing bolts between the vacuum pump and the pallet/base plate



CAUTION

Do not walk, work or stand under suspended loads.

- Attach lifting gear to a crane hook equipped with a safety latch
- Lift the vacuum pump with a crane hook



CAUTION

Tilting a vacuum pump that is already filled with oil can cause large quantities of oil to flow into the cylinder.

Starting the vacuum pump with excessive quantities of oil in the cylinder will immediately break the lobes and destroy the vacuum pump.

Once the vacuum pump is filled with oil it must not be lifted any more.

- Prior to every transport make sure that the oil has been drained (unless recommended otherwise)

Storage

Short-term Storage

- Make sure that the suction connection/gas inlet and the discharge connection /gas outlet are closed (fit the provided plugs)
- Store the vacuum pump
 - if possible in its original packaging,
 - indoors,
 - dry,
 - dust free
 - vibration free

Switching off and conservation of the pump

Please note TN01175

Removal of the pump

Before starting up a vacuum pump that has been stored outside the building for a while, the vacuum pump must be moved to a room with ambient temperature, where it should rest for a day.

Conservation

In case of adverse ambient conditions (e.g. aggressive atmosphere, frequent temperature changes) the vacuum pump must be preserved after one week using a conservation agent inside the cylinder. In case of favourable ambient conditions, the pump must be preserved using a conservation agent inside the cylinder if the pump is to be stored for more than 3 months.



CAUTION

Using the pump with the gas discharge connection closed will damage the vacuum pump.

Make sure that the gas discharge connection is open.



CAUTION

During operation the surface of the vacuum pump may exceed temperatures of 70°C.

Risk of burns!

Do not touch the hot housing.

- Electrically connect the vacuum pump (see "Installation and Commissioning, Installation, Connect Electrically")

- Dispose of the used oil in compliance with applicable regulations
- Switch off the vacuum pump
- Make sure that the oil level at the gears and bearings is between the MIN and MAX markings of the oil sight glasses
- Make sure that oil level of the drop oiler (b) is in the middle of the oil sight glass.
- Make sure that all openings are firmly closed; seal all openings that are not closed with PTFE-tape, gaskets or o-rings, with adhesive tape.
- Wrap the vacuum pump in VCI film

NOTE: VCI stands for "Volatile Corrosion Inhibitor". VCI-products (film, paper, cardboard, foam) evaporate a substance that condenses in molecular thickness on the packed good and by its electrochemical properties effectively suppresses corrosion on metallic surfaces. However, VCI-products may attack the surfaces of plastics and elastomers. Seek advice from your local packaging dealer! VCI packaging ensures good protection against corrosion for a few years, even in the most extreme of conditions such as see transport and prolonged storage.

- Store the vacuum pump
 - if possible in its original packaging,
 - indoors,
 - dry,
 - dust free and
 - vibration free

Repeat the conservation process after 12 months of standstill.



CAUTION

Before a new conservation process or re-installation of the vacuum pump, make sure that the gasket, plug or adhesive tape from the discharge connection are removed.

Commissioning after conservation

- Make sure that all gaskets, plugs or adhesive tape are removed from the openings
- Make sure that the oil level at the gears and bearings is between the MIN and MAX markings of the oil sight glasses
- Make sure that oil level of the drop oiler (b) is in the middle of the oil sight glass.
- Commission the vacuum pump as described in the chapter "Installation and Commissioning"

Installation and Commissioning

Installation Prerequisites



CAUTION

In case of non-compliance with the installation prerequisites, particularly in case of insufficient cooling :

Risk of damage or destruction of the vacuum pump and adjoining system components!

Risk of injury!

The installation prerequisites must be complied with.

- Make sure that the integration of the vacuum pump is carried out in such a way that the essential safety requirements of the Machine Directive 2006/42/EC are complied with (regarding the responsibility of the designer of the machinery into which the vacuum pump is to be incorporated; see also the note in the EC-Declaration of Conformity)



WARNING

Please take into account that the running blower may induce vibrations and sound emission in the pipework and foundations.

Therefore isolation- and sound protection measures must be considered in the planning stage already.

Safety precautions and technical documents of your component suppliers must be observed, if you carry out the planning of a system and/ or installation of the blower stage on your own!

Local installation

- Make sure that the vacuum pump is switched off and cannot accidentally be switched on again
- Make sure that the following ambient conditions are adhered to:
 - Ambient temperature : see "Oil"
 - Ambient pressure: atmospheric
- Make sure that the environmental conditions comply with the protection class of the drive motor (according to the nameplate)
- Make sure that the vacuum pump is placed on or fastened to a horizontal surface
- Make sure that the vacuum pump is level and even
- Make sure that the vacuum pump cannot inadvertently or intentionally be used as a support for heavy objects
- Make sure that the vacuum pump cannot be hit by falling objects
- Make sure that the vacuum pump is at least 0,5m away from any wall to ensure sufficient cooling
- Make sure that no temperature-sensitive components (plastics, wood, cardboard, paper, electronics) come into direct contact with the hot surface of the vacuum pump
- Make sure that the installation site or assembly area is ventilated in such a way that adequate cooling of the vacuum pump is guaranteed



CAUTION

During operation the surface of the vacuum pump can exceed temperatures of 70°C.

Risk of burns!

- Make sure that the vacuum pump cannot be touched inadvertently during operation, provide a guard if necessary
- Make sure that the oil sight glasses (f,80) remain easily accessible

If the oil change is meant to be performed on site:

- ◆ Make sure that the oil drain plugs (g) and the oil filler plugs (c) remain easily accessible

Suction Connection



CAUTION

Do not put hands into the inlet aperture.

Risk of body damage!



CAUTION

The ingress of foreign particles or liquids can destroy the vacuum pump.

In case the inlet gas contains dust or other foreign solid particles :

- ◆ Make sure that a suitable filter is installed upstream of the vacuum pump

- Make sure that the suction line fits the suction flange/gas inlet of the vacuum pump
- Make sure that the vacuum pump is switched off and cannot accidentally be switched on again

When using pipes :

- ◆ Make sure that the pipe does not exercise any pressure on the vacuum pump's connection, use bellows if necessary
- ◆ Make sure that distance on the sealing surfaces on each side does not exceed 0,05 mm
- Make sure that the suction line's diameter on its entire length is at least as large as the diameter of the suction connection/gas inlet(d) of the vacuum pump

If two or more vacuum pumps work on the same suction line, if the volume of the vacuum system is large enough to draw back oil after having been switched off, or if the vacuum must be maintained after switching off the vacuum pump :

- ◆ Provide a manually or automatically operated valve (=non-return valve) in the suction line

(the non-return valve installed as standard inside the suction connection is not meant to be used for this purpose!)

If the vacuum pump is intended to be used for the drawing of gases that contain limited quantities of condensable vapour :

- ◆ Provide a shut-off valve, a drain line and a drain tap in the suction line, so that condensates can be drained from the suction line
- Make sure that the suction line does not contain foreign matter, e.g. welding slag

Discharge connection



CAUTION

Do not put hands into the outlet aperture.

Risk of body damage!

The following guidelines for the discharge line do not apply if the drawn air is discharged into the environment directly at the vacuum pump.

- Make sure that the discharge line fits the gas discharge of the vacuum pump

When using pipes:

- ◆ Make sure that the pipe does not exercise any pressure on the discharge connection, use bellows if necessary
- Make sure that the discharge line's diameter over its entire length is at least as large as the diameter of the gas discharge of the vacuum pump

In case of very long discharge lines, it is advisable to use a larger diameter piping in order to avoid a loss in efficiency and an overload on the vacuum pump. For advice please contact your local Busch representative!

- Make sure that the discharge line either slopes away downwards from the vacuum pump or provide a liquid separator or a drain line with a drain tap, so that no liquids can be drawn back into the vacuum pump



WARNING

Discharge lines made from non-conducting material can build up electrostatic charge.

Electrostatic discharge can lead to explosion of potentially present oil mist.

The discharge line must be made of conducting material or provisions must be made against electrostatic discharge.

Drive/ Coupling

- The shaft end must be cleaned from conservation oil prior to assembly
- Sharp edges on shaft or coupling must be broken / deburred.
- Couplings must be slipped onto the shaft end with the help of a mounting device and a threaded rod.
- The mounting device / threaded rod is to be screwed into the metric centering thread of the driving shaft.



CAUTION

Do not install with hammer blows! Risk of bearing damage!

Coupling must be secured against axial displacement after assembly.

Coupling alignment

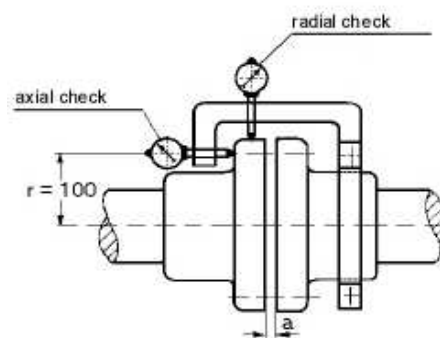

Concentric running of the coupling must be checked axially and radially using measuring gauges. Install coupling and spacers up to the stop. Check alignment to the driving coupling half by means of measuring gauges or an edge.

Concentricity tolerances:

- Radial: max. 0,05 mm on the shaft (0,1 mm on pulley radius)
- Axial: max. 0,05 mm on pulley radius
 - ◆ At a distance $r=100$ mm from shaft centre.
 - ◆ Concerning other distances the tolerances must be converted proportionally.

Electrical connection/ Controls

- Make sure that the regulations acc. to the EMC-Directive 2014/30/EU as well as the EN-standards, electrical and occupational safety directives and the local or national regulations, respectively, are complied with (this is in the responsibility of the designer of the machinery into which the vacuum pump is to be incorporated; see also the note in the EC-Declaration of Conformity)
- Make sure that the power supply is compatible with the specification on the nameplate of the drive motor
- Make sure that an overload protection according to EN 60204-1 is provided for the drive motor
- Make sure that the drive of the vacuum pump will not be affected by electric or electromagnetic disturbance from the mains; if necessary contact the Busch service for advice

In case of mobile installation :

- ◆ Make sure that the vacuum pump is switched off and cannot accidentally be switched on again
- If the Roots blower is used in a vacuum system where a vacuum pump is connected upstream, the vacuum pump can only be started up after the primary pump has gone into operation.

Installation

Fitting

- Make sure that the "Installation Prerequisites" are complied with
- Fit or mount the vacuum pump at its final location

Electrical connection



WARNING

Risk of electrical shock, risk of damage to equipment.

Electrical installation work must only be executed by qualified personnel that knows and observes the following regulations:

- IEC 364 or CENELEC HD 384 or DIN VDE 0100, respectively,
- IEC-Report 664 or DIN VDE 0110,
- BGV A2 (VBG 4) or corresponding national accident prevention regulations.



CAUTION

The wiring diagrams given below are typical. Depending on specific purchase orders or certain markets different wiring diagrams may apply

Risk of damage to the drive motor!

The inside of the terminal box must be checked for correct drive motor wiring diagrams/instructions.

- Electrically connect the drive motor
- Connect the earth

Triangle connection (low voltage):

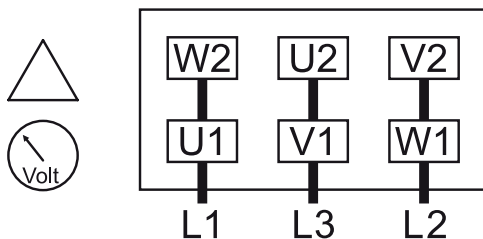

Star connection (high voltage):

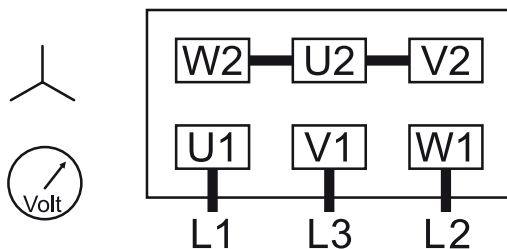

CAUTION

Operation in the wrong direction of rotation of the motor will destroy the vacuum pump within a very short period of time.

Risk of explosion of the drive motor!

Prior to starting-up make sure that the vacuum pump is to be operated in the right direction.

- Make sure that the vacuum pump is switched off and cannot accidentally be switched on again
- Switch on the drive motor for a fraction of a second only
- Watch the fan of the drive motor and determine the direction of rotation just before the fan stops

If the direction of rotation of the fan must be changed:

- ◆ Switch around any two of the drive motor wires in the terminal box

Operation with frequency converter

- In case a frequency converter is provided, the electrical and mechanical characteristics of the drive motor must be taken into account.
- The minimum frequency must always be set to a specified value. This frequency must not be undercut during operation .
- The maximum frequency must be set, taking into account the maximum motor speed and the maximum rotational speed of the vacuum pump.
- The acceleration time of the drive motor from standstill up to minimum speed may be 3 to 6 seconds.
- The frequency converter must be designed for operation with a machine with constant torque. Min.- or max. rotational speeds must not be exceeded or undercut.
- The highest admissible rate of voltage increase for the motor converter is 1200 V/ μ s. When exceeding this value, e.g. due to excessively long cables, the frequency converter type etc., a motor throttle / motor filter coil compatible with the frequency converter must be fitted. Leaving out any of these components may lead to damage of the motor insulation and to a motor breakdown.
- The max. rotational speed alteration rate for vacuum pumps after acceleration to min. speed for upward and downward regulation time is 1 Hz per second.
Min. frequency = 20Hz
Max. frequency = 50Hz results in a regulation time of 30 seconds from min. to max. frequency.
- The max. current limit of the motor must not be exceeded. Follow the information on the motor nameplate.
- In order to avoid any problems during operation, the function "interception circuit" must not be parametrised in the supervision of the frequency converter. When switching off the frequency converter, a re-start is only permitted after a complete standstill of the vacuum pump.

With pole-changing motor

Between every change of motor speed:

- From high to low rotational speed the motor must have reached zero speed every time
- Switching from low to high rotational speed switching can be done directly and instantaneously.

Connecting lines/ piping

In case the suction line is equipped with a shut-off valve :

- ◆ Connect the suction line
- Connect the discharge line

- Make sure that cooling air inlets and outlets are not covered or obstructed and that the cooling air flow can circulate without obstruction

Filling up with Oil

The gears and the bearings are oil-lubricated.

In case the pump has been preserved with conservation oil:

- ◆ Drain any remaining conservation liquids (see "Maintenance, Draining the Oil")



CAUTION

The vacuum pump is always shipped without oil.

Operation without oil will destroy the vacuum pump within a very short period of time.

Prior to commissioning the vacuum pump, make sure that oil is filled in.

The vacuum pump is delivered without oil (oil specification see "Oil").

The application of the vacuum pump will determine the oil to be used.



CAUTION

In case of a change-over from mineral to a fully synthetic oil an oil change has to be carried out after 50 operating hours.

This even applies for initial filling with synthetic oil as the machines are tested with a mineral oil.

Dispose of the used oil according to applicable environmental protection regulations.

NOTE: The quantity of oil given in these operating instructions serves as a guideline only. Check the oil level with the help of the oil sight glasses (f,80) on the vacuum pump.



CAUTION

Before changing the oil type, compatibility must be checked and, if necessary, the pump must be flushed.



CAUTION

In case the vacuum pump has been treated with conservation oil:

Synthetic oils (except for oils based on poly-olefin) are incompatible with mineral oils and conservation oils.

Risk of foam building leading to the destruction of the vacuum pump.



CAUTION

Oil may only be filled in through oil filler holes (c).

Remove oil filler plugs (c) only if the vacuum pump and the primary pump are at a complete standstill.

The vacuum pump must only be operated with the oil filler plugs (c) firmly tightened up.

- Make sure that the oil drain plugs (g) are closed
- Remove oil filler plugs (c)
- Fill in the relevant quantity of oil as detailed in the table "Oil Quantity"
- When using mineral oil, make sure that the oil level at the gears and bearings is in the middle of the oil sight glasses. When using

Fomblin oil, make sure that the oil level stands at 2/3 in the oil sight glasses.

- Make sure that the oil level of the drop oiler (b) is in the middle of the reservoir



CAUTION

Depending on the model, the drop oiler is also supplied as an "optional accessory" and must be fitted prior to filling up.

Prior to fitting, remove the plug of the connection pipe and screw in the drop oiler together with a corresponding seal.

- Make sure that the seals of the oil drain plugs (g) are not damaged and positioned correctly. Replace seals if damaged.
- Refit the oil filler plugs (c) together with the seals
- Switch on the vacuum pump

In case the suction line is equipped with a shut-off valve:

- ◆ Close the shut-off valve

In case the suction line is not equipped with a shut-off valve:

- ◆ Cover the suction flange with a rubber mat (d)
- Let the vacuum pump run for a few minutes
- Switch off the vacuum pump and wait for a few minutes
- When using mineral oil, make sure that the oil level at the gears and bearings is in the middle of the oil sight glasses. When using Fomblin oil, make sure that the oil level stands at 2/3 in the oil sight glasses.
- Make sure that the oil level of the drop oiler (b) is in the middle of the reservoir



CAUTION

The oil level in the transparent reservoir may increase due to the influence of heat.

If the oil level has dropped below the MIN- marking of the oil sight glass.

- ◆ Top-up with oil

In case the suction line is equipped with a shut-off valve:

- ◆ Open the shut-off valve

In case the suction line is not equipped with a shut-off valve:

- ◆ Remove the rubber mat from suction flange and connect the suction line

Saving the Operating Parameters

Make sure that the vacuum pump and the primary pump are switched off and cannot accidentally be switched on again.

- Measure the working current of the drive motor and keep it as reference value for all future maintenance and repair work

Water-cooled seal ring housing

On vacuum pumps with water-cooled seal housing the cooling water supply is to be connected prior to commissioning.

Preconditions to water-cooling:

- Water pressure max. 6 bar
- water inlet temperature max. 35°C
- water outlet temperature max. 50°C
- ΔT to be set between inlet and outlet: min. 4K
- Any cooling water flow reduction must be on the outlet side
- water quality: as per works standard TN01153
- Electrical conductivity: 100-150 μs/cm

- ◆ pH-values (25°C): 8-9
- ◆ Hardness (°d): 2-3
- ◆ Chlorides: 1 mg/l (<100mg/l no flocks contained)
- ◆ Mineral shares (salt content): <0,02 mg/l (silicic acid, iron, alkaline earths)
- ◆ Oxygen (O₂): <0,5 mg/l, (on open reservoirs not possible; 7,8 mg/l saturation)
Alternatives: e.g. heat up to 90° then cool down or evacuate.
- ◆ Filter fineness: 10 µm
- ◆ Coating material: chromium oxide
- Provide corrosion protection inhibitors in cooling water

Water quantities:

Profile 10-20: approx. 5 l/min

Recommendation:

Concerning danger of frost the cooling water should be provided in addition with an antifreezing compound

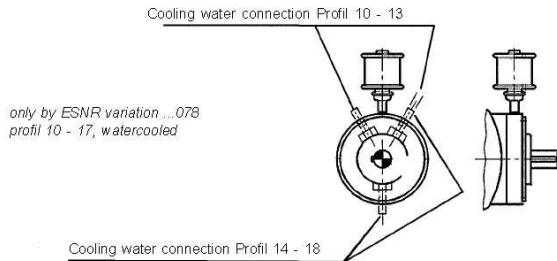

Recommendations on operation

Application



CAUTION

The vacuum pump is designed for operation under the conditions described below.

In case of disrespect of the above, risk of damage or destruction of the vacuum pump and adjacent system components!

Risk of Injury!

The vacuum pump must only be operated under the conditions described below.

The vacuum pump has been designed for

- the suction
- of
- air and other dry, non-aggressive, non-toxic and non-explosive gases.

The Roots vacuum pumps are usually used in conjunction with other types of primary pumps in vacuum systems.

Drawing substances with a higher density than air leads to an increased thermal and mechanical load on the vacuum pump and is permissible only after consultation with Busch.

Max. allowed temperature of the drawn gas:

See "Oil, Ambient temperature range"

Dispose of the used oil according to applicable environmental protection regulations.

Max. permissible number of startings per hour: 6.

The vacuum pump is thermally suitable for continuous operation.

The vacuum pump is ultimate pressure- proof.

The pumping of other vapours must be previously approved by the Busch Company.



CAUTION

During operation the surface of the vacuum pump may exceed temperatures of 70°C.

Risk of burns!

The vacuum pump must be protected against contact during operation, provide a guard if necessary



CAUTION

The vacuum pump emits sound of high intensity.

Risk of hearing damage.

Users spending a longer period of time in the vicinity of a non-insulated vacuum pump must wear suitable hearing protection.

- Make sure that the vacuum pump and the primary pump are switched off and cannot accidentally be switched on again.
- Make sure that protective devices will not be disconnected
- Make sure that cooling air inlets and outlets are not covered or obstructed and that the cooling air flow can circulate without obstruction
- Make sure that the "Installation Prerequisites" (see "Installation Prerequisites and Commissioning") are followed, particularly follow those instructions that ensure sufficient cooling

New start after shut-down under working pressure (high end pressure):

After a shut-down under working pressure the WPA Vacuum Pump should be started anew only after previous ventilation of the installation.

Otherwise there is a risk that the internal shaft seal will be damaged. During shut-down under working pressure, the supporting lubricating film under the lip seal collapses due to the high force between the sealing lip and the shaft sleeve. Therefore, when starting anew under working pressure, there will be insufficient lubrication at the sealing lip for a little while. Therefore, prior to each new start under working pressure, Ateliers Busch recommends to ventilate the installation until there is almost atmospheric pressure within the oil chambers. This procedure guarantees that the pressure drop and consequently the force between the sealing lip and the shaft sleeve of the internal shaft seal is kept to a minimum.

If, nevertheless, there has to be a start under working pressure, increased wear of the internal shaft seal has to be taken into account. The changing intervals of the shaft seals are likely to be shortened. After having reached the working pressure, it is therefore recommended to maintain a certain minimum rotational speed. This will ensure a sufficient oil supply to the gears and bearings without shut-down of the installation. The minimum rotational speeds below are applicable for the following operational cases :

- Short-time high-vacuum operation for max. 30 min. (e.g. frequency converter operation)



CAUTION

Continuous operation not permissible.

Risk of contact problems of the rotary lobes due to overheating !

- Operation without motor, rotary lobes rotate due to the drawn volume flow.

Minimum rotational speeds (1/min.)

WPA 040 A	(Profile 14)	500
WPA 055 A / WPA 075 A	(Profile 15)	500
WPA 095	(Profile 16)	500

Heatable Roots vacuum pump WPA

When using Roots pump versions with double-walled side plates, these plates are filled with the heating agent. Permissible heating media are steam, oil or recycled water.

Max. admissible heating agent temperature: 110°C.

Max. admissible heating agent pressure: 2,0 mbar(g).



CAUTION

Risk of burns!

Limitations of use

ΔP =differential pressure between the outlet and the inlet of the vacuum pump. See table "Technical Characteristics". Do not exceed the values given in the table.

Maintenance



ANGER

When the vacuum pump has been drawing toxic gases or gases contaminated with toxic substances, the pump itself may be contaminated with toxic substances.

These foreign materials can infiltrate the pores, recesses and other internal spaces of the vacuum pump.

Danger to health when checking or cleaning the vacuum pump, or when individual components are changed on or within the vacuum pump.

Danger to the environment.

Always wear protective clothing when carrying out maintenance work.

Contaminated vacuum pumps are special waste and must be disposed of in accordance with current and local environmental laws.

For all maintenance work, the vacuum pump or the vacuum system must be switched off and it must be ensured that it cannot accidentally be switched on again.

Any dismantling of the pump must be executed by qualified personnel only. Before dismantling, the end user of the vacuum pump must fill in a "Declaration of Contamination of Vacuum Equipment and Components" which will inform about possible risks and dangers and corresponding measures.

Without this document duly filled in and signed by an authorised person, the pump cannot be dismantled.



CAUTION

During operation, the surface of the vacuum pump may exceed temperatures of 70°C.

Risk of burns!

- Prior to any work that requires touching the vacuum pump, let the vacuum pump cool down

When draining the oil:

- ◆ Let the vacuum pump cool down for no more than 20 minutes

- Prior to disconnecting the inlet or discharge lines, make sure that these pipes/lines have been vented to atmospheric pressure

When contacting the Ateliers Busch After Sales Service concerning maintenance, servicing or overhaul of a Roots WPA vacuum pump, please keep the following information to hand:

- Purchase order- and serial numbers
- Describe any failures / malfunctions as detailed as possible
- Describe the steps taken so far to remove the failure

Maintenance Schedule

NOTE: The maintenance intervals depend very much on the individual operating conditions. The intervals given below must be considered as starting values which should be shortened or extended as appropriate. Particularly heavy duty operation, e.g. high dust loads in the environment or in the process gases, other contaminations or ingress of process material, can make it necessary to shorten the maintenance intervals significantly.

Weekly

- Check the oil level (see "Checking the oil")

Monthly:

- Make sure that the vacuum pump and the primary pump are switched off and cannot be accidentally be switched on again
- Check the vacuum pump for oil leaks - in case of leaks have the vacuum pump repaired (Busch service)

In case of operation in a dusty environment:

- ◆ Make sure that the working area is free from dust and dirt, clean if necessary
- ◆ Check and clean the motor fan if necessary

After the first 500 operating hours

- Drain the oil of the gears and the bearing housings (see "Draining the Oil")

After each 4000 operating hours, latest every year

- Drain the oil of the gears and the bearing housings (see "Draining the Oil")
- Drain the oil of the seal housing (see "Draining the Oil")

Every 20000 operating hours, at the latest after 3 Years

- Have a major overhaul done on the vacuum pump (Busch service)

Checking the oil

Checking the oil level at the gears and bearing housings

Oil level with mineral oil:

- Make sure that the vacuum pump and the primary pump are switched off and cannot accidentally be switched on again
- Read the level on the oil sight glasses (f,80)

In case the level is above the MAX-marking:

- ◆ Change the oil (see "Change the oil")

Dispose of the used oil in compliance with applicable environmental protection regulations.

Oil level with Fomblin oil:

- Make sure that the vacuum pump and the primary pump are switched off and cannot accidentally be switched on again
- Read the level on the oil sight glasses (f,80)
- Make sure that the oil level at the gears and bearing housings stands at 2/3 in the oil sight glasses

Dispose of the used oil in compliance with applicable regulations.

Checking the oil level in the seal housing

- Make sure that the vacuum pump is switched off and cannot accidentally be switched on again
- Check the oil level of the drop oiler (b)

If either an excessive rise or drop in the oil level of the drop oiler is noticed, please check for possible causes under chapter "Troubleshooting".

Dispose of the used oil in compliance with applicable regulations.

Topping up with oil

NOTE: Under normal conditions, there should be no need to top up with oil during the recommended oil change intervals. A significant level drop indicates a malfunction (see "Troubleshooting").



CAUTION

Make sure that the vacuum pump is switched off and cannot accidentally be switched on again. Please fill in the oil after removing the oil filler plugs on the cylinder covers.

- Remove oil filler plugs
- Top up with oil until the oil level is in the middle of the oil sight glasses (Mineral oil)
- When using mineral oil, make sure that the oil level at the gears and bearings is in the middle of the oil sight glasses. When using Fomblin oil, make sure that the oil level stands at 2/3 in the oil sight glasses.
- Make sure that oil level of the drop oiler (b) is in the middle of the oil sight glass
- Refit the oil filler plugs (c)
- Make sure that the oil filler plugs have been correctly fitted after filling in the oil, so that no air can enter the pump. Too high an oil level must be avoided as well as this could lead to overheating of the gears.
- Please always use a new seal



CAUTION

We recommend submitting the pump to leakage rate test in order to ensure the pump is leak tight.

Checking the colour of the oil

NOTE: The oil should have a light colour and can be transparent, a little foamy or a little clouded. A milky discolouration that does not vanish after the oil has been left to rest indicates contamination with foreign material. Darkly coloured oil has either been contaminated with foreign material or burnt and must be changed (see "Oil Change").

Life span of the oil at the gears and the bearings

The oil life depends very much on the operating conditions. A clean and dry air stream and operating temperatures below 100°C are ideal. Under these conditions the oil and the oil filter must be changed every 4000 operating hours, latest after 6 months.

Under very unfavourable operating conditions the oil life can be less than 500 operating hours. Extremely short life times indicate malfunctions (see "Troubleshooting") or unsuitable operating conditions.

If there is no experience available regarding the oil life under the prevailing operation conditions, it is recommended to have an oil analysis carried out every 1000 operating hours and establish the oil change interval accordingly thereafter.

Life span of the oil in the seal housing

The oil life depends very much on the operating conditions. A clean and dry air stream and operating temperatures below 100°C are ideal. Under these conditions, the oil must be changed latest after 4000 operating hours or one year.

Under very unfavourable operating conditions the oil life can be less than 500 operating hours. Extremely short life times indicate malfunctions (see "Troubleshooting") or unsuitable operating conditions.

If there is no experience available regarding the oil life under the prevailing operation conditions, it is recommended to have an oil analysis carried out every 1000 operating hours and establish the change interval accordingly thereafter.

Oil Change



WARNING

When the vacuum pump has been drawing toxic gases or gases contaminated with toxic substances, the pump itself may be contaminated with toxic substances.

Danger to health when checking or cleaning the vacuum pump, or when individual components are changed on or within the vacuum pump.

Danger to the environment.

When working on, or handling, a contaminated pump, suitable and appropriate safety clothing must be worn.

Contaminated vacuum pumps are special waste and must be disposed of in accordance with current and local environmental laws.

Draining used oil from the gears and the bearings

NOTE: After switching off the vacuum pump at normal operating temperature, wait no more than 20 minutes before draining the oil.



CAUTION

When draining the oil, the oil temperature must not exceed 60°C.

Risk of burns!

- Make sure that the vacuum pump and the primary pump are switched off and cannot accidentally be switched on again
- Make sure that the vacuum pump is vented to atmospheric pressure
- Put a drain tray underneath the oil drain plugs (g)
- Remove the oil drain plugs (g)
- Drain the oil

When the oil flow has stopped:

Make sure that all the used oil is drained

- Make sure that the seal of the oil drain plug is not damaged and fits correctly. Please always use a new seal.
- Refit the oil drain plugs (g)
- Dispose of the used oil in compliance with applicable regulations

Draining used oil from the seal housing

NOTE: After switching off the vacuum pump at normal operating temperature, wait no more than 20 minutes before the oil is drained.

- Make sure that the vacuum pump and the primary pump are switched off and cannot accidentally be switched on again

- Check the oil level of the drop oiler (b)
- Remove the oil drain plug (g)
- Drain the oil

When the oil flow has stopped:

Make sure that all the used oil is drained

- Refit the oil drain plug (g)
- Dispose of the used oil in compliance with applicable regulations

Filling in fresh oil for the gears and the bearings



CAUTION

In case of a change-over from mineral to a fully synthetic oil, an oil change has to be carried out after 50 operating hours.

Replace the shaft seals at the driving shaft, if necessary.

In this case, the housing of the gears and bearing seals must be filled with the same oil and an oil change must be carried out after 50 operating hours.

- Prepare the necessary oil quantity (see table "Oil quantity")

NOTE: The quantity given in these operating instructions serves as a guideline only. Check the oil level with the help of the oil sight glasses (f,80) on the vacuum pump.

- Make sure that oil drain plugs (c) have been correctly fitted and are tight



CAUTION

Oil may be filled through oil filler holes only.

- Remove the oil filler plugs (c)
- Fill in the new oil up to the middle of the oil sight glasses (f,80) (Mineral oil)
- Fill in the new oil up to 2/3 of the oil sight glasses (f,80) (Fomblin oil)
- Make sure that the seals have been fitted to the oil filler plugs (c) and are undamaged, replace if necessary.
- Refit the oil filler plugs (c)
- Dispose of the used oil in compliance with applicable regulations

Filling in fresh oil for the seal housing



CAUTION

In case of a change-over from mineral to a fully synthetic oil, an oil change has to be carried out after 50 operating hours.

Replace the shaft seals at the driving shaft.

In this case, the housing of the gears and bearing seals must be filled with the same oil and an oil change must be carried out after 50 operating hours.

- Prepare the oil quantity needed (see table "Oil quantity")
- Remove the drop oiler (b)
- Fill the seal housing with oil right up to the beginning of the threading of the drop oiler



ATTENTION

Oil may be filled through oil filler hole only.

- Refit the drop oiler (b)
- Remove the flap (b) of the drop oiler

- Fill the drop oiler (b) reservoir up to the middle.

Overhaul



ATTENTION

In case of a change-over from mineral to a fully synthetic oil, an oil change has to be carried out after 50 operating hours.



CAUTION

In order to achieve the highest degree of efficiency and a long life span, the vacuum pump has been assembled and adjusted in accordance with precisely defined tolerances.

This adjustment will be lost during dismantling of the vacuum pump.

It is therefore highly recommended that any dismantling of the vacuum pump going beyond the scope of description in this manual should be carried out by specially trained Busch service personnel only.



CAUTION

Risk for the operating safety after improper work on the vacuum pump.

Risk of explosion!

Approval for operation of the pump will be void!

Any dismantling of the vacuum pump going beyond the scope of what is described in this manual must be carried out by specially trained Busch service personnel only.



WARNING

Prior to shipping the vacuum pump, it must be decontaminated as thoroughly as possible and the contamination status must be documented in a "Declaration of Contamination" (form downloadable from www.busch-vacuum.com).

Busch service will only accept vacuum pumps that come with a completely filled in and legally binding signed "Declaration of Contamination" (form downloadable from www.busch-vacuum.com).

Removal from Service

Temporary preservation

- Prior to disconnecting the inlet and discharge lines, make sure that all pipes have been vented to atmospheric pressure

Recommissioning

After longer periods of standstill:

- ◆ Make sure that the vacuum pump and the primary pump are switched off and cannot accidentally be switched on again
- ◆ Remove the fan cover of the drive motor
- ◆ Slowly rotate the fan by hand a few times in the intended direction of rotation (see arrow sticker or cast arrow on the fan cover)
- ◆ Refit the fan cover of the drive motor, in case it might have been removed previously during maintenance work or when removing the pump from service.
- Follow the instructions in chapter "Installation and Commissioning"

Dismantling and Disposal



WARNING

Prior to shipping the vacuum pump, it must be decontaminated as thoroughly as possible and the contamination status must be documented in a "Declaration of Contamination" (form downloadable from www.busch-vacuum.com).

- Drain the oil
 - ◆ Dispose of the used oil in compliance with applicable regulations
- Make sure that all materials and components that must be treated as special waste have been removed from the vacuum pump
- Make sure that the vacuum pump is not contaminated with any harmful foreign material

Based on what is known at the time of print of this manual, the materials used for the manufacturing of the vacuum pump involve no risk.

- Please dispose of used parts and fluids in accordance with local applicable environmental laws and regulations
- Dispose of the vacuum pump as scrap metal

Exploded view

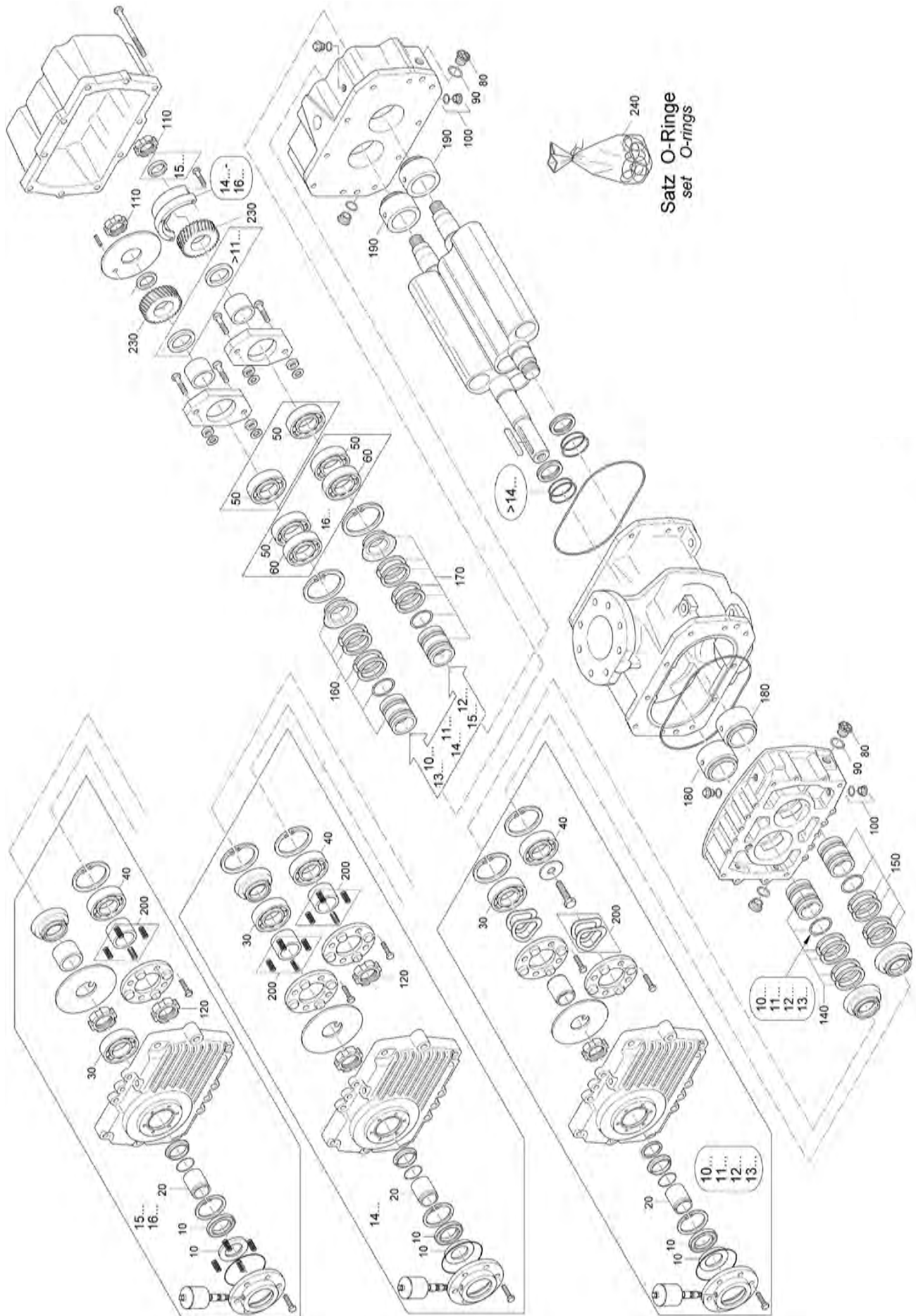

Full service kit

These full service kits contain all relevant gasket kits as well as the wear and tear parts that need to be changed.

WPA 040 A	0993 561 987
WPA 055 A	0993 561 988
WPA 075 A	0993 561 989
WPA 080 A	0993 561 990
WPA 095 A	0993 564 801

Oil

Oil for the gears and bearings

Oils with the following characteristics must be used:

- Non-ageing mineral oils or fully synthetic oils with good, natural corrosion- and ageing protection
- Lubrication oils which fulfill the minimum requirements according to: Type CL as per DIN 51 517 part 2
- The lubrication oils must not exceed a vapour pressure of 1×10^{-4} mbar at 100°C
- In case of outdoor installation, make sure that the yield point (solidifying point) of the mineral oil used is below the lowest ambient temperature

Examples of oil types / Proven comparable qualities may also be used	
Brand	Oil type
ARAL	Motanol HV 100
EXXON / MOBIL	Nuto H 100
SHELL	Corena V
CASTROL	Tribol 800 / 100 *

* Fully synthetic oil (Polyglycol), see also lube oil conversion

Oil for seal housing

- ARAL Motanol HV 100 / filled in at the factory
- Oils which are listed in the above chart "Examples of oils"

Gear Housing and bearing seals housing / seal housing	Total oil quantity (in Liter)
WPA 040 A	7
WPA 055 A	12
WPA 075 A	12
WPA 080 A	11
WPA 095 A	11

Technical Data

Technical Properties - WPA 040 A			3000 min-1	3600 min-1
Nominal displacement	50/ 60 Hz	m ³ /h	3850	4700
Max. differential pressure (standard)	50/ 60 Hz	hPa (mbar)	75	75
Nominal motor rating (standard)	50/ 60 Hz	kW	11	11
Max. differential pressure (Heavy duty)	50/ 60 Hz	hPa (mbar)	100	100
Nominal motor rating (Heavy duty)	50/ 60 Hz	kW	15	15

Technical Properties - WPA 055 A			3000 min-1	3600 min-1
Nominal displacement	50/ 60 Hz	m ³ /h	5500	6650
Max. differential pressure (standard)	50/ 60 Hz	hPa (mbar)	80	80
Nominal motor rating (standard)	50/ 60 Hz	kW	15	15
Max. differential pressure (Heavy duty)	50/ 60 Hz	hPa (mbar)	100	53
Nominal motor rating (Heavy duty)	50/ 60 Hz	kW	18.5	18.5

Technical Properties - WPA 075 A			3000 min-1	3600 min-1
Nominal displacement	50/ 60 Hz	m ³ /h	7350	8950
Max. differential pressure (standard)	50/ 60 Hz	hPa (mbar)	100	53
Nominal motor rating (standard)	50/ 60 Hz	kW	18.5	18.5

Technical Properties - WPA 080 A			1500 min-1	1800 min-1
Nominal displacement	50/ 60 Hz	m ³ /h	8000	9800
Max. differential pressure (standard)	50/ 60 Hz	hPa (mbar)	75	75
Nominal motor rating (standard)	50/ 60 Hz	kW	18.5	18.5
Max. differential pressure (Heavy duty)	50/ 60 Hz	hPa (mbar)	80	80
Nominal motor rating (Heavy duty)	50/ 60 Hz	kW	22	22

Technical Properties - WPA 095 A			1500 min-1	1800 min-1
Nominal displacement	50/ 60 Hz	m ³ /h	9535	11675
Max. differential pressure (standard)	50/ 60 Hz	hPa (mbar)	75	75
Nominal motor rating (standard)	50/ 60 Hz	kW	22	22

Troubleshooting



WARNING

Risk of electrical shock, risk of damage to equipment.

Electrical installation work must only be carried out by qualified personnel that know and observe the following regulations:

- IEC 364 or CENELEC HD 384 or DIN VDE 0100, respectively,
- IEC-Report 664 or DIN VDE 0110,
- BGV A2 (VBG 4) or equivalent national accident prevention regulations.



CAUTION

During operation the surface of the vacuum pump may exceed temperatures of 70°C.

Risk of burns!

Let the vacuum pump cool down prior to touching or wear heat protection gloves.

Please contact your local Busch representative if you have any doubts or questions

Problem	Possible Cause	Remedy
Abnormal running sounds	Lobes dirty or contaminated	Clean the lobes
	Friction of the lobes on each other or on the casing	Check tolerance adjustments/ check for cracks
	Foreign particles in the gears	Clean gears
	Shaft out of true	Measure shaft deflection Check flank tolerance of the gears
	Bearing damage	Replace the bearings
The vacuum pump is too hot	Inlet filter clogged	Clean the filter
	Ambient temperature too high	Provide sufficient room ventilation/ incoming and outgoing air
	Oil level or viscosity too high	Correct/ drain
	Excessive wear of rotors and consequently increase of tolerances	Have the vacuum pump repaired (Busch service)
	Overloaded	Stick to the operational data
Oil in drawn air	Too much oil in oil chambers	Drain, clean pump process chamber
Inlet volume too low	Inlet screen/ inlet filter clogged	Clean or change the filter
	Leakage of the pipes	Find and stop leaks
	Incorrect vacuum pump size	Compare with performance diagram
	Considerable wear of lobes	Have the vacuum pump repaired (Busch service)
Excessive current consumption of motor (please refer to documents of the system's manufacturer)	Operational data differ from purchase order data	Compare performance data with measured values
	Mechanical damage to vacuum pump or motor	Repair (Busch Service)
	Motor voltage has dropped	Adjust power, refer to motor instructions
The vacuum pump runs in reverse direction after switch-off	Non-return valve defective or leaky	Replace the non-return valve

After each intervention on the vacuum pump due to failure, check :

- Easy-running
- Rotation without friction
- Correct operation



CAUTION

In case of any resistances, the vacuum pump must not be operated!

After start-up observe the blower thoroughly !

Keep to the lubrication periods for bearings of the electric motors. Please refer to the lubrication period plate on the electric motor or to the instructions of the motor manufacturer. For all drive motors with a Busch nameplate the operating instructions of the manufacturer must be followed.

EU Declaration of Conformity

This Declaration of Conformity and the CE-mark affixed to the nameplate are valid for the machine within the Busch scope of delivery. This Declaration of Conformity is issued under the sole responsibility of the manufacturer. When this machine is integrated into a superordinate machinery the manufacturer of the superordinate machinery (this can be the operating company, too) must conduct the conformity assessment process for the superordinate machine or plant, issue the Declaration of Conformity for it and affix the CE-mark.

The manufacturer

**Ateliers Busch S.A.
Zone Industrielle
CH-2906 Chevenez**

declares that the machine(s) **PUMA WPA 040/ 055/ 075/ 080/ 095 A**

fulfil(s) all the relevant provisions from European directives:

- 'Machinery' 2006/42/EC
- 'Electromagnetic Compatibility' 2014/30/EU
- 'RoHS' 2011/65/EU Restriction of the use of certain hazardous substances in electrical and electronic equipment (incl. all related applicable amendments)

and comply(-ies) with the following designated standards that have been used to fulfil those provisions:

Standard	Title of the Standard
EN ISO 12100 : 2010	Safety of machinery - Basic concepts, general principles of design
EN ISO 13857 : 2019	Safety of machinery - Safety distances to prevent hazard zones being reached by the upper and lower limbs
EN 1012-1 : 2010 EN 1012-2 : 1996 + A1 : 2009	Compressors and vacuum pumps - Safety requirements - Part 1 and Part 2
EN ISO 2151 : 2008	Acoustics - Noise test code for compressors and vacuum pumps - Engineering method (grade 2)
EN 60204-1 : 2018	Safety of machinery - Electrical equipment of machines - Part 1: General requirements
EN IEC 61000-6-2 : 2019	Electromagnetic compatibility (EMC) - Generic standards. Immunity for industrial environments
EN IEC 61000-6-4 : 2019	Electromagnetic compatibility (EMC) - Generic standards. Emission standard for industrial environments
EN ISO 13849-1 : 2015 ⁽¹⁾	Safety of machinery - Safety-related parts of control systems - Part 1: General principles for design

⁽¹⁾ In case control systems are integrated.

Legal person authorized to compile the technical file
and authorized representative in the EU
(if the manufacturer is not located in the EU):

Busch Dienste GmbH
Schauinslandstr. 1
DE-79689 Maulburg

Chevenez, 14.05.2021



Christian Hoffmann, General Director

UK Declaration of Conformity

This Declaration of Conformity and the UKCA-mark affixed to the nameplate are valid for the machine within the Busch scope of delivery. This Declaration of Conformity is issued under the sole responsibility of the manufacturer. When this machine is integrated into a superordinate machinery the manufacturer of the superordinate machinery (this can be the operating company, too) must conduct the conformity assessment process for the superordinate machine or plant, issue the Declaration of Conformity for it and affix the UKCA-mark.

The manufacturer

**Ateliers Busch S.A.
Zone Industrielle
CH-2906 Chevenez**

declares that the machine(s) **PUMA WPA 040/ 055/ 075/ 080/ 095 A**

fulfil(s) all the relevant provisions from UK legislations:

- Supply of Machinery (Safety) Regulations 2008
- Electromagnetic Compatibility Regulations 2016
- Restriction of the use of certain hazardous substances in electrical and electronic equipment Regulations 2012

and comply(-ies) with the following designated standards that have been used to fulfil those provisions:

Standard	Title of the Standard
BS EN ISO 12100 : 2010	Safety of machinery. Basic concepts, general principles of design. Risk assessment and risk reduction.
BS EN ISO 13857 : 2019	Safety of machinery - Safety distances to prevent hazard zones being reached by the upper and lower limbs.
BS EN 1012-1 : 2010 BS EN 1012-2 : 1996 + A1 : 2009	Compressors and vacuum pumps. Safety requirements. Air compressors and vacuum pumps.
BS EN ISO 2151 : 2008	Acoustics - Noise test code for compressors and vacuum pumps - Engineering method (grade 2)
BS EN 60204-1 : 2018	Safety of machinery. Electrical equipment of machines. General requirements.
BS EN IEC 61000-6-2 : 2019	Electromagnetic compatibility (EMC) - Generic standards. Immunity standard for industrial environments.
BS EN IEC 61000-6-4 : 2019	Electromagnetic compatibility (EMC) - Generic standards. Emission standard for industrial environments.
BS EN ISO 13849-1 : 2015 ⁽¹⁾	Safety of machinery. Safety-related parts of control systems. General principles for design.

⁽¹⁾ In case control systems are integrated.

Legal person authorized to compile the technical file
and importer in the UK
(if the manufacturer is not located in the UK):

Busch (UK) Ltd
30 Hortonwood
Telford - UK

Chevenez, 14.05.2021



Christian Hoffmann, General Director

Note

Busch

Vacuum Solutions

We shape vacuum for you.

Argentina

info@busch.com.ar

Australia

sales@busch.com.au

Austria

busch@busch.at

Bangladesh

sales@busch.com.bd

Belgium

info@busch.be

Brazil

vendas@buschdobrasil.com.br

Canada

info@busch.ca

Chile

info@busch.cl

China

info@busch-china.com

Colombia

info@buschvacuum.co

Czech Republic

info@buschvacuum.cz

Denmark

info@busch.dk

Finland

info@busch.fi

France

busch@busch.fr

Germany

info@busch.de

Hungary

busch@buschvacuum.hu

India

sales@buschindia.com

Ireland

sales@busch.ie

Israel

service_sales@busch.co.il

Italy

info@busch.it

Japan

info@busch.co.jp

Korea

busch@busch.co.kr

Malaysia

busch@busch.com.my

Mexico

info@busch.com.mx

Netherlands

info@busch.nl

New Zealand

sales@busch.co.nz

Norway

post@busch.no

Peru

info@busch.com.pe

Poland

busch@busch.com.pl

Portugal

busch@busch.pt

Romania

office@buschromania.ro

Russia

info@busch.ru

Singapore

sales@busch.com.sg

South Africa

info@busch.co.za

Spain

contacto@buschiberica.es

Sweden

info@busch.se

Switzerland

info@buschag.ch

Taiwan

service@busch.com.tw

Thailand

info@busch.co.th

Turkey

vakutek@ttmail.com

United Arab Emirates

sales@busch.ae

United Kingdom

sales@busch.co.uk

USA

info@buschusa.com