

# R5 RB/RC 0021 C

Oil-lubricated rotary vane vacuum pumps



Discover all advantages of the product series R5 RB

## Compact

Reduced height and weight, ideal for installations in confined spaces

## Reliable

Robust construction, highly durable fiber-reinforced epoxy resin vanes, proven rotary vane technology, long service life

## Flexible

Various design options available, easy adaption to individual customer requirements and processes

### Accessories

- Gas-ballast valve
- Various inlet filters
- Filter pressure gauge
- Vacuum pump oils for all applications
- Vacuum regulating unit

# R5 RB/RC 0021 C

Oil-lubricated rotary vane vacuum pumps



## Dimensional drawing

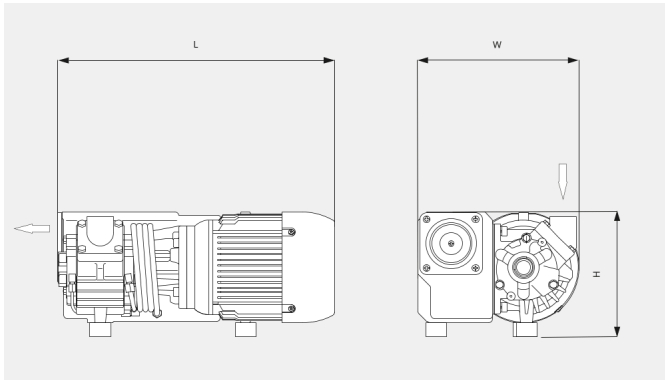

## Pumping speed

Air at 20 °C. Tolerance: ± 10%

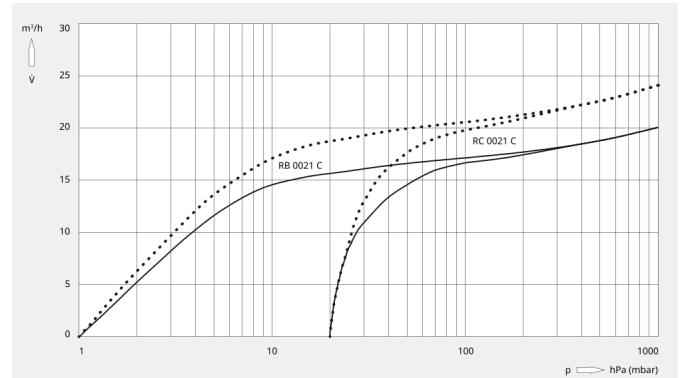

The following technical values refer to ISO 50 Hz

	R5 RB 0021 C	R5 RC 0021 C
Nominal pumping speed	20 m³/h	20 m³/h
Ultimate pressure	1.0 hPa (mbar)	20.0 hPa (mbar)
Nominal motor rating	0.75 kW	0.75 kW
Nominal motor speed	3000 min <sup>-1</sup>	3000 min <sup>-1</sup>
Sound pressure level (ISO 2151)	66 dB(A)	66 dB(A)
Oil capacity	0.45 l	0.45 l
Weight approx.	20 kg	20 kg
Dimensions (L x W x H)	401 x 229 x 180 mm	401 x 229 x 180 mm
Gas outlet	–	–
Gas inlet	G ½"	G ½"

The following technical values refer to ISO 60 Hz

	R5 RB 0021 C	R5 RC 0021 C
Nominal pumping speed	24 m³/h	24 m³/h
Ultimate pressure	1.0 hPa (mbar)	20.0 hPa (mbar)
Nominal motor rating	0.9 kW	0.9 kW
Nominal motor speed	3600 min <sup>-1</sup>	3600 min <sup>-1</sup>

# R5 RB/RC 0021 C

Oil-lubricated rotary vane vacuum pumps



	R5 RB 0021 C	R5 RC 0021 C
Sound pressure level (ISO 2151)	72 dB(A)	72 dB(A)
Oil capacity	0.45 l	0.45 l
Weight approx.	20 kg	20 kg
Dimensions (L x W x H)	401 x 229 x 180 mm	401 x 229 x 180 mm
Gas outlet	–	–
Gas inlet	G ½"	G ½"

## DO YOU WANT TO KNOW MORE

Please contact us!  
sales@busch.com.au or +61 (0)1800 639 087



CONTACT FORM



CALL US NOW