

# R5 RA 0155 A

Oil-lubricated rotary vane vacuum pump



VACUUM SOLUTIONS



## Reliable

Robust construction, highly durable fiber-reinforced epoxy resin vanes, proven rotary vane technology, long service life

## High performance

High pumping speed at low pressures, designed for continuous operation in the rough vacuum range

## Flexible

Easy adaption to individual customer requirements and processes, level and temperature switch as standard

### Accessories

- Gas-ballast valve
- Various inlet filters
- Adapter flange for vacuum booster
- Filter pressure gauge
- Vacuum pump oils for all applications
- Oil level switch
- Temperature sensors
- Starter unit
- Oxygen version

# R5 RA 0155 A

Oil-lubricated rotary vane vacuum pump



VACUUM SOLUTIONS

Dimensional drawing

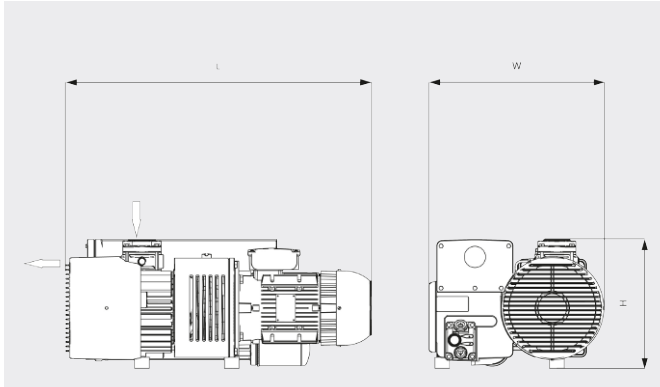

Pumping speed

Air at 20°C. Tolerance: ± 10%

— 50 Hz ..... 60 Hz

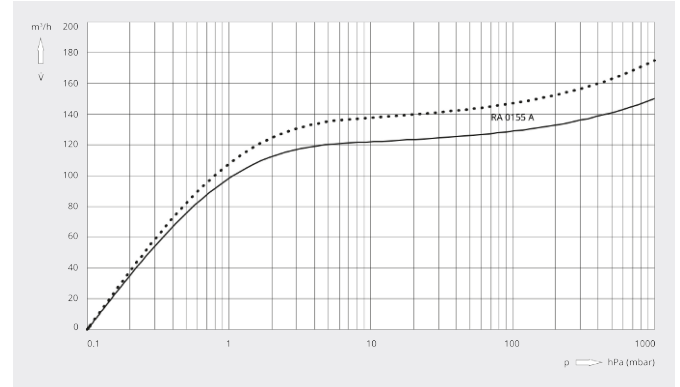

R5 RA 0155 A	
Nominal pumping speed	150 / 175 m³/h (50 / 60 Hz)
Ultimate pressure	0.1 hPa (mbar) (50 / 60 Hz)
Nominal motor rating	4.0 / 4.2 kW (50 / 60 Hz)
Nominal motor speed	1500 / 1800 min <sup>-1</sup> (50 / 60 Hz)
Power consumption at 100 mbar	3.2 / 3.8 kW (50 / 60 Hz)
Power consumption at ultimate pressure	2.1 / 2.5 kW (50 / 60 Hz)
Noise level (ISO 2151)	70 / 72 dB(A) (50 / 60 Hz)
Oil capacity	3.5 l
Weight approx.	110 kg
Dimensions (L x W x H)	765 x 470 x 340 mm
Gas inlet / outlet	G 2" / G 2"

## DO YOU WANT TO KNOW MORE?

Get in touch with us directly!  
[sales@busch.com.au](mailto:sales@busch.com.au) or 1 800 639 087



CONTACT FORM



CALL NOW