

# R5 KD 0025 A

Oil-lubricated rotary vane vacuum pump



VACUUM SOLUTIONS



## Compact

Direct-drive construction, reduced height and weight, specially designed for table top packaging machines

## High performance

Fast pump-down times, high vapor tolerance, excellent condensation protection, optimum temperature management

## Easy servicing

Fast service routine, long service intervals, smooth surface design for easy cleaning

# R5 KD 0025 A

Oil-lubricated rotary vane vacuum pump



VACUUM SOLUTIONS

Dimensional drawing

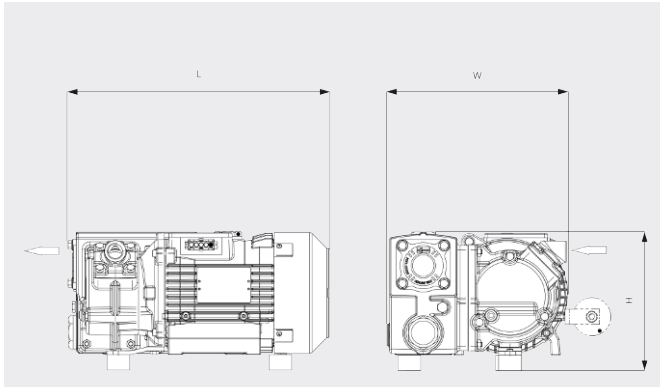

Pumping speed

Air at 20°C. Tolerance: ± 10%

— 50 Hz ..... 60 Hz

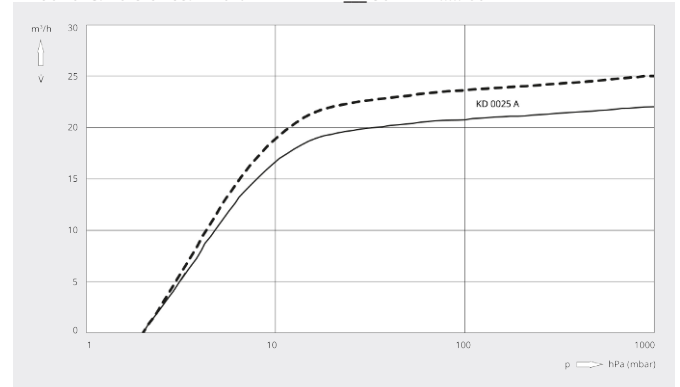

	R5 KD 0025 A short separator	R5 KD 0025 A long separator
Nominal pumping speed	22 / 25 m³/h (50 / 60 Hz)	22 / 25 m³/h (50 / 60 Hz)
Ultimate pressure	2.0 hPa (mbar) (50 / 60 Hz)	2.0 hPa (mbar) (50 / 60 Hz)
Nominal motor speed	0.75 / 0.9 kW (50 / 60 Hz)	0.75 / 0.9 kW (50 / 60 Hz)
Nominal motor speed	3000 / 3600 min <sup>-1</sup> (50 / 60 Hz)	3000 / 3600 min <sup>-1</sup> (50 / 60 Hz)
Noise level (ISO 2151)	62 / 67 dB(A) (50 / 60 Hz)	64 / 68 dB(A) (50 / 60 Hz)
Oil capacity	0.3 l	0.45 l
Weight approx.	21 kg	21 kg
Dimensions (L x W x H)	339 x 235 x 180 mm	338 x 232 x 187 mm
Gas inlet / outlet	G ½" / G ½"	G ½" / G ½"

## DO YOU WANT TO KNOW MORE?

Get in touch with us directly!  
[sales@busch.com.au](mailto:sales@busch.com.au) or 1 800 639 087



CONTACT FORM



CALL NOW