

# R5 RA 1000/1600 A PLUS

Oil-lubricated rotary vane vacuum pumps



VACUUM SOLUTIONS



## Control and monitoring

Ready for Industry 4.0 providing remote control, condition monitoring and communication protocols

## Cost savings

Reduced energy consumption and minimized operating costs

## Proven technology

Reliable operation thanks to R5 rotary vane vacuum technology

# R5 RA 1000/1600 A PLUS

Oil-lubricated rotary vane vacuum pumps



VACUUM SOLUTIONS

Dimensional drawing

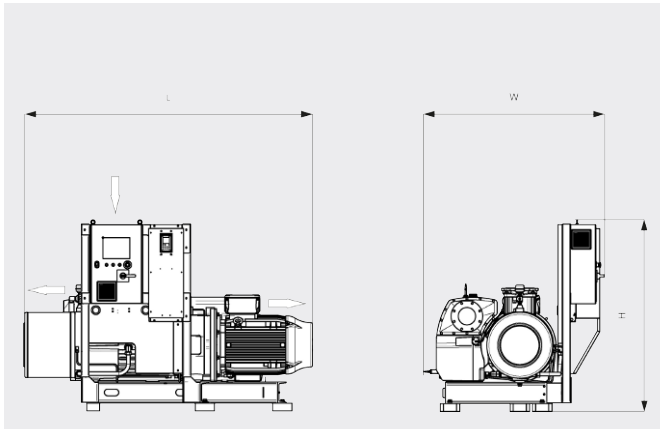

Pumping speed

Air at 20°C. Tolerance: ± 10%

— Min. speed ..... Max. speed

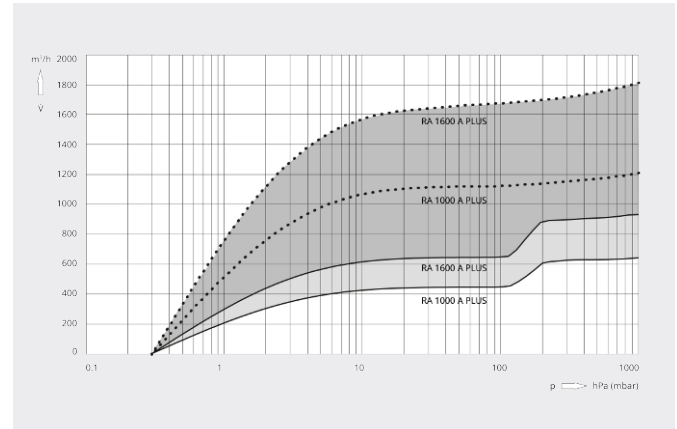

	R5 RA 1000 A PLUS	R5 RA 1600 A PLUS
Nominal pumping speed	440 – 1200 m <sup>3</sup> /h	640 – 1800 m <sup>3</sup> /h
Ultimate pressure	0.3 hPa (mbar)	0.3 hPa (mbar)
Nominal motor rating	30 kW	37 kW
Nominal motor speed	500 – 1200 min <sup>-1</sup>	500 – 1200 min <sup>-1</sup>
Power consumption at 100 mbar	8.6 – 22.3 kW	12.8 – 35.9 kW
Power consumption at ultimate pressure	5.4 – 12.5 kW	6.9 – 19.0 kW
Noise level (ISO 2151)	65 – 79 dB(A)	69 – 83 dB(A)
Oil capacity	30 l	30 l
Weight approx.	1230 kg	1580 kg
Dimensions (L x W x H)	1964 x 1422 x 1451 mm	2198 x 1422 x 1451 mm
Gas inlet / outlet	DN 150 / DN 125	DN 150 / DN 125

DO YOU WANT TO KNOW MORE?

Get in touch with us directly!  
[sales@busch.com.au](mailto:sales@busch.com.au) or 1 800 639 087



CONTACT FORM



CALL NOW