

# TAPIR HL 1102 A

Leak detector



## Portable

Compact, retractable handle, lightweight, integrated detachable control panel, can be operated at any position

## High performance

Highly sensitive leak detection, minimum detectable leakage rate of  $5 \cdot 10^{-13}$  Pa · m<sup>3</sup>/s, for almost all applications, spray test and sniffing leak detection with helium or hydrogen

## Control and monitoring

High definition color display for maximum readability, intuitive menu navigation, SD memory card for saving and downloading all relevant data, customizable parameter settings

### Accessories

- Helium spray gun kit
- Sniffing probe
- Transport trolley
- Transport box
- Power connection, 2.5 m, UK

# TAPIR HL 1102 A

Leak detector



Dimensional drawing

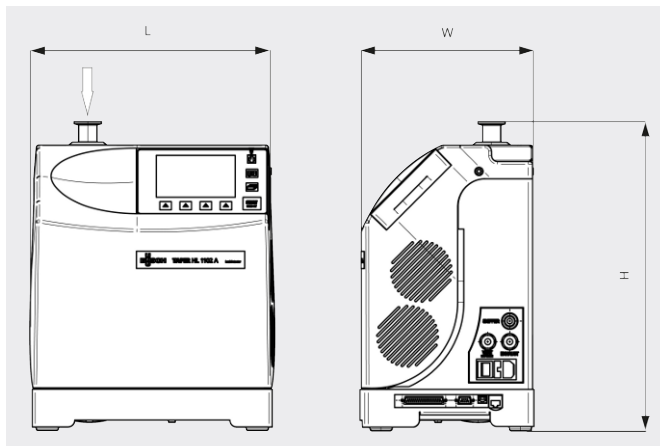

TAPIR HL 1102 A	
Pumping speed for helium	1.1 l/s
Response time (sniffing leak detection)	< 1 s
Minimum detectable leakage rate for helium (spray test)	$5 \cdot 10^{-13} \text{ Pa} \cdot \text{m}^3/\text{s}$
Minimum detectable leakage rate for helium (sniffing leak detection)	$1 \cdot 10^{-8} \text{ Pa} \cdot \text{m}^3/\text{s}$
Detectable gases	$^4\text{He}$ ; $^3\text{He}$ ; $\text{H}_2$
Test method	Spray test and sniffing leak detection
Start-up time (20 °C) with calibration	< 3.5 min
Start-up time (20 °C) without calibration	< 2 min
Backing pump	Diaphragm vacuum pump
Pumping speed of backing pump (50 Hz)	1.7 m <sup>3</sup> /h
Max. power consumption	300 W
Power supply	90–240 V (50/60 Hz)
I/O interfaces	RS-232; standard 15 pins I/O
Operating temperature (sniffing test)	10–40 °C
Operating temperature (spray test)	10–40 °C

# TAPIR HL 1102 A

Leak detector



VACUUM SOLUTIONS

TAPIR HL 1102 A	
Noise level (ISO 2151)	< 45 dB(A)
Weight approx.	21 kg
User interface	Color touch screen (detachable)
Dimensions (L x W x H)	350 x 254 x 415 mm
Connecting flange	DN 25 ISO-KF

## DO YOU WANT TO KNOW MORE?

Get in touch with us directly!  
[sales@busch.com.au](mailto:sales@busch.com.au) or 1 800 639 087



CONTACT FORM



CALL NOW