

DOLPHIN LG 0890/1200 A

Liquid ring vacuum pumps



VACUUM SOLUTIONS



Robust

Proven technology, reliable operation, extremely high vapor and particle tolerance, specially designed for challenging environments like mining, power plants, sugar production, pulp and paper industry, steel production etc.

High performance

High-capacity, high pumping speeds

Flexible

Modular design, choice of cast iron (EN-GJL-200) housing with ductile cast iron impeller or all 316 grade corrosion-free stainless steel material, operating fluids other than water possible, operation as compressor possible

Accessories

- Motorized pumpsets, with gearbox or V-belt drive system, mounted on sturdy steel base frames
- Partial or total recirculation systems
- Cavitation protection
- Gas ejector
- Non-return valves
- Vacuum relief valves

DOLPHIN LG 0890/1200 A

Liquid ring vacuum pumps



VACUUM SOLUTIONS

Dimensional drawing

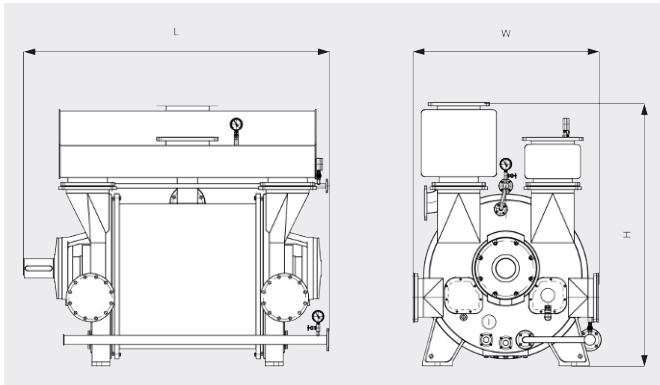

Pumping speed

Air at 20°C. Tolerance: ± 10%

— 50 Hz 60 Hz

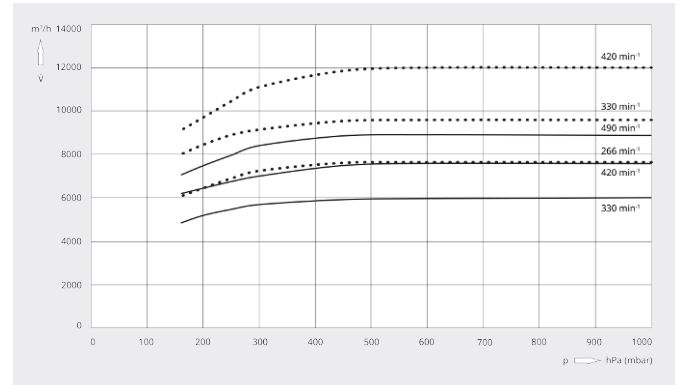

	DOLPHIN LG 0890 A	DOLPHIN LG 1200 A
Nominal pumping speed	6000 – 8900 m ³ /h	7650 – 12000 m ³ /h
Ultimate pressure	160 hPa (mbar)	160 hPa (mbar)
Nominal motor rating	132 – 220 kW	160 – 280 kW
Nominal motor speed	330 – 490 min ⁻¹	266 – 420 min ⁻¹
Noise level (ISO 2151)	< 85 dB(A)	< 85 dB(A)
Weight approx.	3880 kg	5760 kg
Dimensions (L x W x H)	2370 x 1330 x 1865 mm	2500 x 1550 2160 mm
Gas inlet / outlet	DN 300 PN 10 / DN 300 PN 10	DN 350 PN 10 / DN 350 PN 10

DO YOU WANT TO KNOW MORE?

Get in touch with us directly!
sales@busch.com.au or 1 800 639 087



CONTACT FORM



CALL NOW