

DOLPHIN LX 0030-0055 B

Liquid ring vacuum pumps

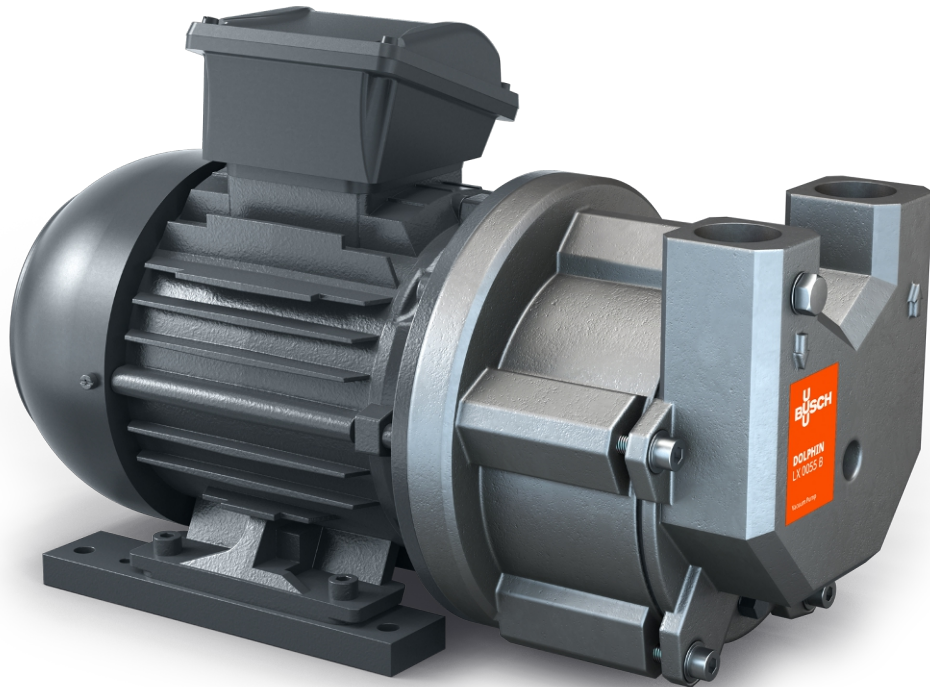

VACUUM SOLUTIONS



Robust

Proven technology, reliable operation, extremely high particle and vapor tolerance, corrosion-free stainless steel impeller

Compact

Directly flanged motor, no base frame required

Flexible

Choice of cast iron (EN-GJL-200) or 316 grade stainless steel material housings, ATEX-certified version available (Cat. 2 (i) IIB, T4), operating fluids other than water possible

Accessories

- Partial or total recirculation systems
- Liquid separator
- Cavitation protection
- Heat exchanger
- Gas ejector
- Wide selection of motors
- Non-return valves
- Vacuum relief valves
- Different operating fluids possible

DOLPHIN LX 0030-0055 B

Liquid ring vacuum pumps



VACUUM SOLUTIONS

Dimensional drawing

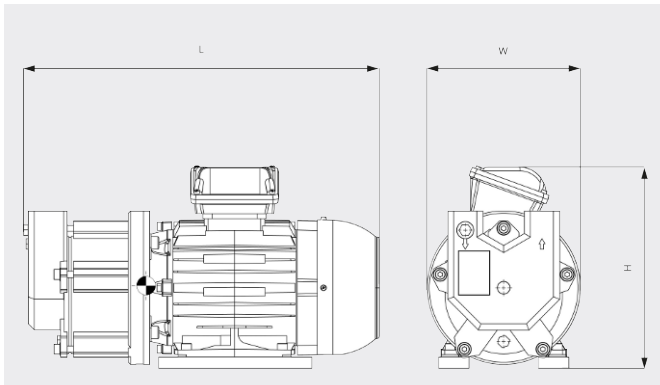

Pumping speed

Dry air at 20 °C. Operating fluid water 15°C. Tolerance: - 10%, in accordance with HEI and Pneurop 6612

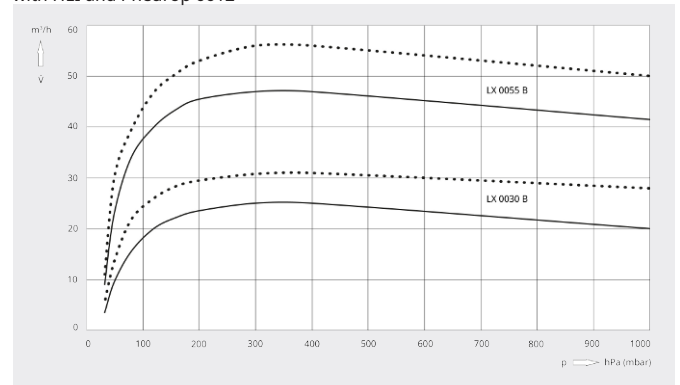

	DOLPHIN LX 0030 B	DOLPHIN LX 0055 B
Nominal pumping speed	25 / 31 m³/h (50 / 60 Hz)	45 / 56 m³/h (50 / 60 Hz)
Ultimate pressure	33 hPa (mbar) (50 / 60 Hz)	33 hPa (mbar) (50 / 60 Hz)
Nominal motor rating	1.1 / 1.5 kW (50 / 60 Hz)	1.5 / 2.2 kW (50 / 60 Hz)
Weight approx.	29 / 37 kg (50 / 60 Hz)	39 / 47 kg (50 / 60 Hz)
Dimensions (L x W x H)	369 x 200 x 250 mm	413 x 200 x 265 mm
Gas inlet / outlet	G 1" / G 1"	G 1" / G 1"

DO YOU WANT TO KNOW MORE?

Get in touch with us directly!
sales@busch.com.au or 1 800 639 087



CONTACT FORM



CALL NOW