

# Instruction Manual

## COBRA

Combi Screw Vacuum Pumps and Boosters

DS 8163 B



# Table of Contents

<b>Preface</b> . . . . .	<b>2</b>
COBRA DS 8163 B . . . . .	3
COBRA DS 8163 B . . . . .	4
COBRA DP 600 C . . . . .	5
Roots WY 075 . . . . .	6
DS 8163 B with equipment . . . . .	7
<b>Product description</b> . . . . .	<b>9</b>
Use . . . . .	9
Operating principle . . . . .	9
Structure . . . . .	10
Oil circulation . . . . .	10
Cooling . . . . .	10
Nitrogen system . . . . .	10
Optional functions/ Use of available accessories . . . . .	11
On/ Off switch . . . . .	11
<b>Safety</b> . . . . .	<b>11</b>
Intended use . . . . .	11
Safety information . . . . .	11
Noise emission . . . . .	12
Maintenance clearance . . . . .	12
Electrical safety . . . . .	12
Types of Electrical Work . . . . .	12
Type 1 . . . . .	12
Type 2 . . . . .	12
Type 3 . . . . .	12
Type 4 . . . . .	13
Lock Out/ Tag Out procedure (Type 1 of electrical work) . . . . .	13
Safety Lockout procedure . . . . .	13
Emergency off circuit description . . . . .	13
Safety interlock description . . . . .	13
Lock out/ Tag out for hydraulics and pneumatics . . . . .	13
Lock Out/ Tag Out procedure (Type 1 of electrical work) . . . . .	13
Interlock table . . . . .	13
<b>Transportation</b> . . . . .	<b>15</b>
Handling . . . . .	15
Transportation in packed state . . . . .	15
Transportation in unpacked state . . . . .	15
Lifting for DP 0600 C . . . . .	15
<b>Storage</b> . . . . .	<b>15</b>
Removal of the vacuum system . . . . .	15
Preservation . . . . .	15
Start-up of the vacuum system after storage: . . . . .	16
<b>Installation and start-up</b> . . . . .	<b>16</b>
Necessary installation instructions . . . . .	16
Installation site and installation . . . . .	16
Unpacking . . . . .	16
Mounting . . . . .	16
Inlet connection . . . . .	17
Discharge connection . . . . .	17
Cooling water connection . . . . .	17
Nitrogen connection . . . . .	18
Electrical connection/ Checks . . . . .	18
Electrical connection . . . . .	18
Procedure to connect the inline power cable . . . . .	18
Controls/ Function . . . . .	19
Equipment connections (with options) . . . . .	19
Connection of the lines/ pipes . . . . .	19
Filling in cooling liquid . . . . .	19
Checking the direct cooling . . . . .	19
Checking the nitrogen . . . . .	19
Oil filling . . . . .	20
COBRA NS (DP) vacuum pump . . . . .	20
Oil level, pump not operating . . . . .	20
WY (MB) rotary lobes vacuum pump . . . . .	20
Oil level, pump not operating . . . . .	20
COBRA DS vacuum system . . . . .	20
Recommendations on operation . . . . .	21
Application . . . . .	21
Start-up of the vacuum system . . . . .	22
Monitoring equipment . . . . .	22
Switching the vacuum system on/ off . . . . .	22
First start-up of the vacuum system . . . . .	22
Switching the vacuum system off . . . . .	22
Description of the Load Lock operation mode: . . . . .	23

<b>Standard operational time chart</b> . . . . .	<b>24</b>
Signal control mode (Select LL mode = EXTERN) . . . . .	24
Current control mode (Select LL mode = AUTO) . . . . .	25
<b>Maintenance</b> . . . . .	<b>26</b>
Maintenance program . . . . .	26
Daily: . . . . .	26
Weekly: . . . . .	26
Monthly: . . . . .	26
Yearly: . . . . .	27
Every 16000 hours of operation, at the latest after 4 years: . . . . .	27
Lock Out/ Tag out procedure . . . . .	27
Safety Lockout procedure . . . . .	27
<b>Checking the oil</b> . . . . .	<b>27</b>
Checking the oil level . . . . .	27
COBRA NS (DP) vacuum pump . . . . .	27
WY (MB) rotary lobes vacuum pump . . . . .	27
Filling in new oil . . . . .	27
COBRA NS (DP) vacuum pump . . . . .	27
Oil level, pump not operating . . . . .	27
WY (MB) rotary lobes vacuum pump . . . . .	28
Oil level, pump not operating . . . . .	28
Checking the colour of the oil . . . . .	28
Oil change . . . . .	28
Draining used oil . . . . .	28
COBRA NS (DP) vacuum pump . . . . .	28
WY (MB) rotary lobes vacuum pump . . . . .	28
Checking the cooling liquid . . . . .	29
Checking the level of the cooling liquid . . . . .	29
Filling in new cooling liquid . . . . .	29
Refilling cooling liquid . . . . .	29
Draining the cooling liquid . . . . .	29
Checking the cooling water . . . . .	29
Checking the cooling water flow . . . . .	29
Checking the nitrogen . . . . .	29
Checking the nitrogen flow . . . . .	29
Checking the current consumption . . . . .	29
Checking the sound silencer (accessory) . . . . .	29
Checking the leak-protection non-return valve (accessory) . . . . .	30
<b>Overhaul</b> . . . . .	<b>30</b>
<b>Removal from service</b> . . . . .	<b>30</b>
Temporary removal from service . . . . .	30
Recommissioning . . . . .	30
Dismantling and disposal . . . . .	30
<b>Oil type/ quantity</b> . . . . .	<b>31</b>
Oil type . . . . .	31
<b>Oil quantity</b> . . . . .	<b>31</b>
<b>Cooling liquid type/ quantity (DP only)</b> . . . . .	<b>32</b>
Cooling liquid type . . . . .	32
Cooling liquid quantity . . . . .	32
<b>Technical data</b> . . . . .	<b>33</b>
<b>EU-Declaration of Conformity</b> . . . . .	<b>34</b>
<b>UK-Declaration of Conformity</b> . . . . .	<b>35</b>

## Preface

Congratulations on your purchase of the Busch vacuum system. With watchful observation of the field's requirements, innovation and steady development Busch delivers modern vacuum and pressure solutions worldwide.

For the purpose of these instructions, "handling" the vacuum system means the transport, storage, installation, commissioning, influence on operating conditions, maintenance, troubleshooting and overhaul of the vacuum system.

**Prior to handling the vacuum system these operating instructions shall be read and understood. If anything remains to be clarified please contact your Busch representative.**

**Keep these operating instructions and, if applicable, other pertinent operating instructions available on site.**

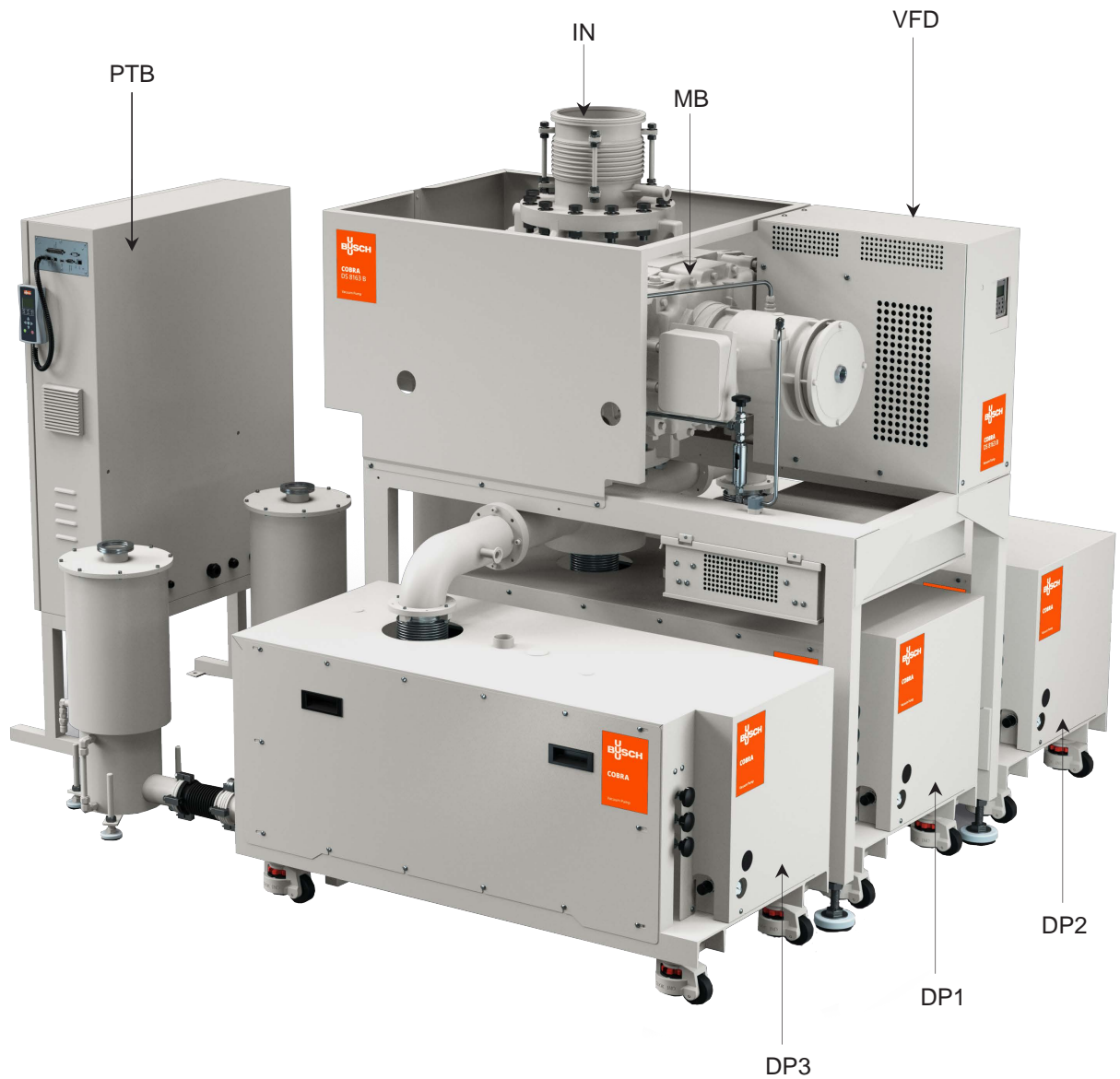

## COBRA DS 8163 B

MB Roots WY 075  
 DP 1 Backing vacuum pump DP 600 C  
 DP 2 Backing vacuum pump DP 600 C  
 DP 3 Backing vacuum pump DP 600 C

IN Inlet  
 MB Roots WY 075  
 PTB Pump terminal box  
 VFD Roots frequency inverter

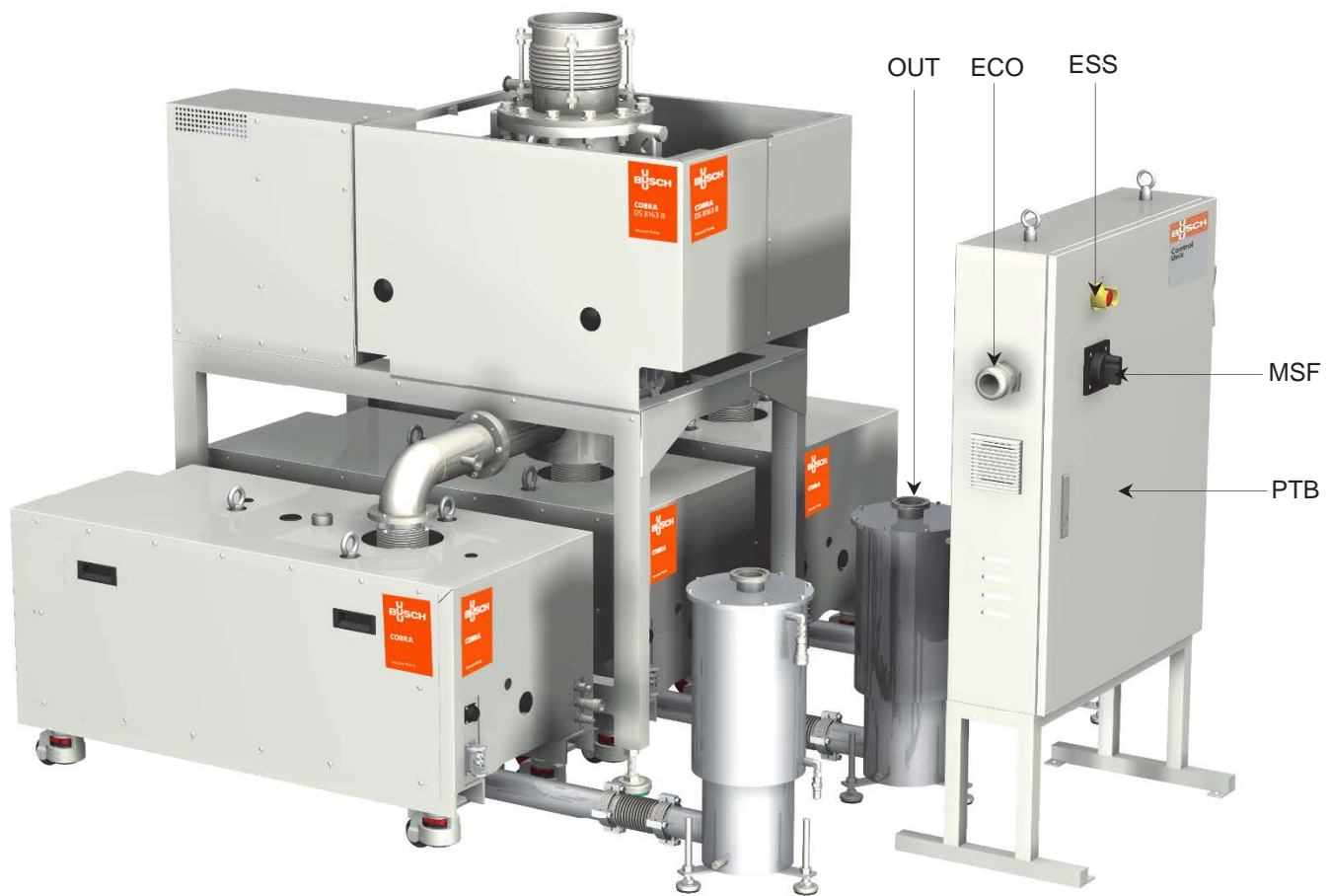

## COBRA DS 8163 B

- ECO Eletrical power supply
- ESS Emergency stop switch
- MSH Main switch
- OUT Discharge
- PTB Pump terminal box

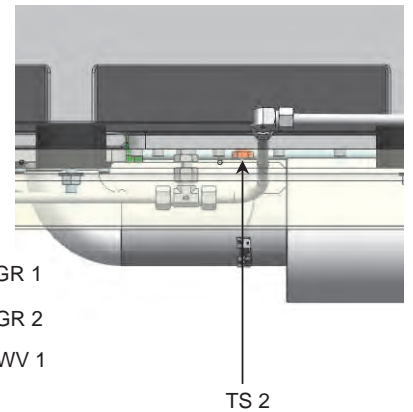
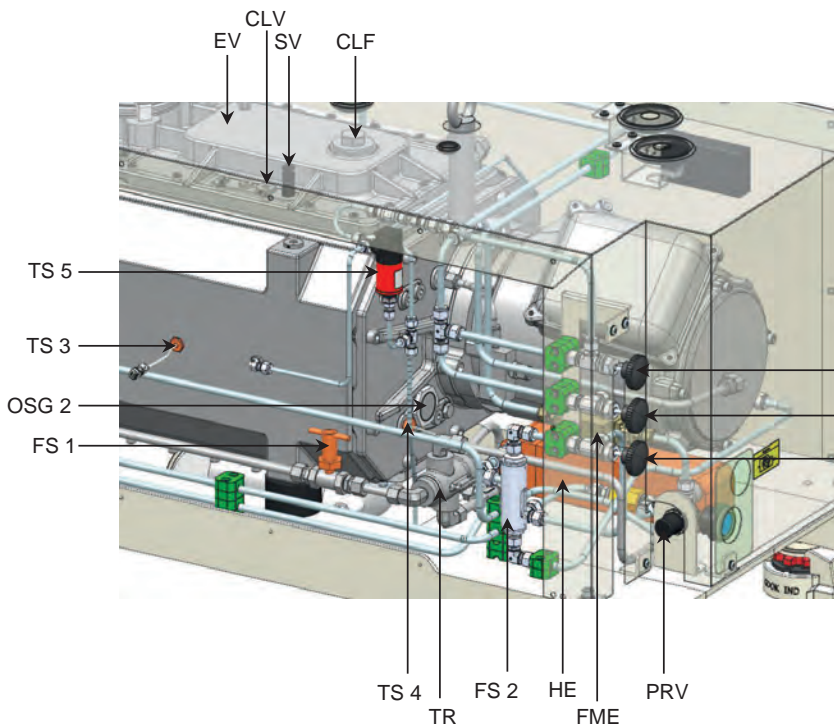
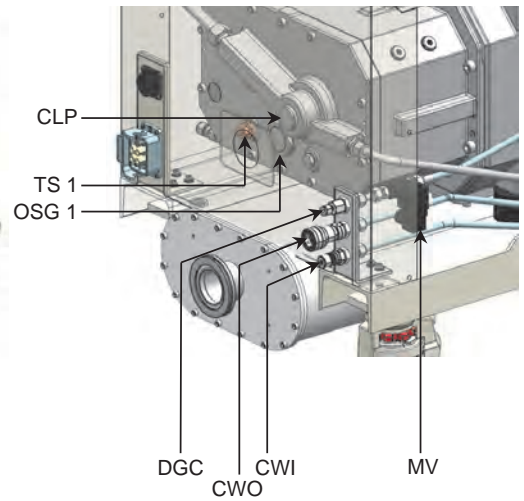

## COBRA DP 600 C

- |   |                                    |  |
|---|------------------------------------|--|
| CLF Cooling liquid filler plug                            | EV Expansion vessel                | PRV Regulating valve, nitrogen                           |
| CLP Glycol circulating pump                               | FME Flow meter, nitrogen           | SV Safety valve  |
| CLV Cooling liquid purge plug                             | FS 1 Flow switch, cooling liquid   | TR Temperature regulator, 55°C                           |
| CWC Cooling water connection (CWi & CWo)                  | FS 2 Flow switch, cooling water    | TS 1 Temperature switch, oil temperature 120°C           |
| CWV 1 Regulating valve, cooling water                     | HE Heat exchanger                  | TS 2 Temperature switch, cooling liquid temperature 100° |
| DGC Nitrogen connection                                   | IN Inlet                           | TS 3 Temperature switch PT100                            |
| DGR 1 Regulating valve, dilution gas (middle of cylinder) | MV Solenoid valve, nitrogen system | TS 4 Temperature switch, oil temperature 140°C           |
| DGR 2 Regulating valve, dilution gas (end of cylinder)    | NC Nitrogen connection             | TS 5 Overpressure sensor                                 |
| ECO Combined power and sensor connection                  | OSG 1 Oil sight glass              | TS 6 Temperature switch, motor 155°C                     |
|   | OSG 2 Oil sight glass              |  |
|   | OUT Discharge (to silencer)        |  |

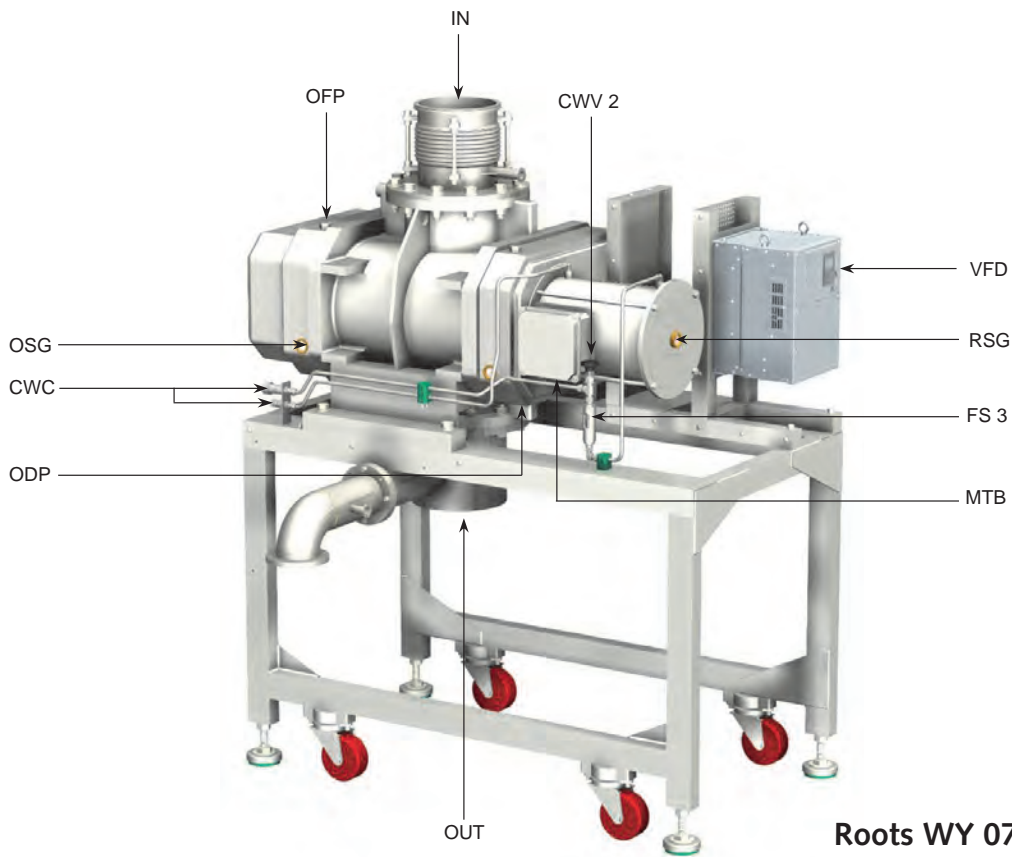

### Roots WY 075

(Roots MB)

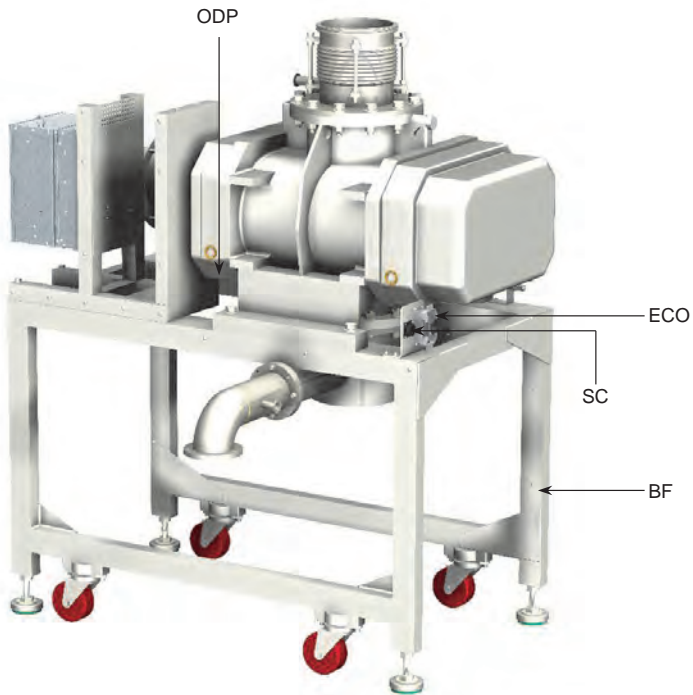

- BF Base frame
- CWC Cooling water connection
- CWV 2 Regulating valve, cooling water
- ECO Electrical connection
- FS 3 Flow switch, cooling water
- IN Inlet
- MTB Motor terminal box
- ODP Oil drain plug
- OFF Oil fill plug
- OSG Oil sight glass
- OUT Discharge/ Distribution for DP pump
- RSG Rotation sight glass
- SC Sensor connection
- VFD Roots Variable frequency drive

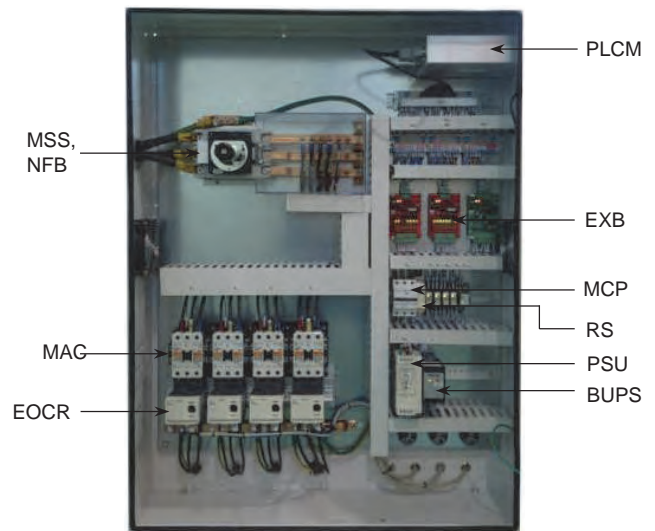

### DS 8163 B with equipment

(lateral electrical box, vertical silencer)

- BUPS Back up power supply
- CWC Cooling water connection
- ECP Ground
- EOCR Electronic Over Current Relay
- EXB Extension board
- PLCM PLC module
- RC Remote control
- MAC Magnetic contactor
- MCP Motor Circuit protector
- MSS Main stop switch
- NFB No Fuse Breaker
- OUT Outlet
- PLCM PLC module
- PSU DC Power supply
- RS Rotation sensor
- SI Vertical silencer with water cooling

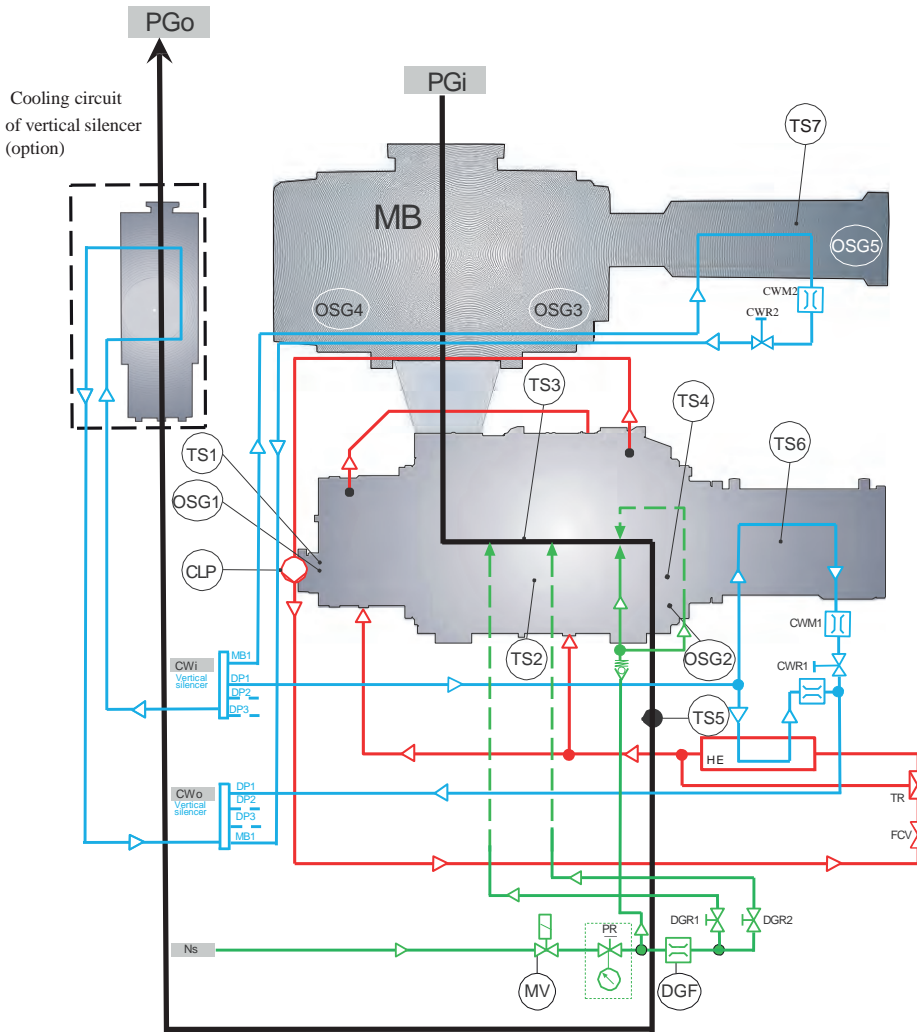

- CLF Cooling liquid filler plug
- CLP Glycol circulating pump
- CLV Cooling liquid purge plug
- CWC Cooling water connection (CWi & CWo)
- CWi, Cooling water inlet
- CWo, Cooling water outlet
- CWV 1 Regulating valve, cooling water
- CWV 2 Regulating valve, cooling water
- DGR 1 Regulating valve, dilution gas (middle of cylinder)
- DGR 2 Regulating valve, dilution gas (end of cylinder)
- ECO Combined power and sensor connection
- EV Expansion vessel
- FME Flow meter, nitrogen
- FS 1 Flow switch, cooling liquid
- FS 2 Flow switch, cooling water
- FS 3 Flow switch, cooling water (4 l/min)
- HE Heat exchanger
- IN Inlet
- MV Solenoid valve, nitrogen system
- NC Nitrogen connection
- OSG 1 Oil sight glass (DP)
- OSG 2 Oil sight glass (DP)
- OSG 3 Oil sight glass, left and right side (MB)
- OSG 4 Oil sight glass (MB)
- OSG 5 Oil sight glass (MB)
- OUT Discharge (to silencer)
- PGi, Process gas inlet
- PGo, Process gas outlet
- PRV Regulating valve, nitrogen
- SV Safety valve
- TR Temperature regulator, 55°C



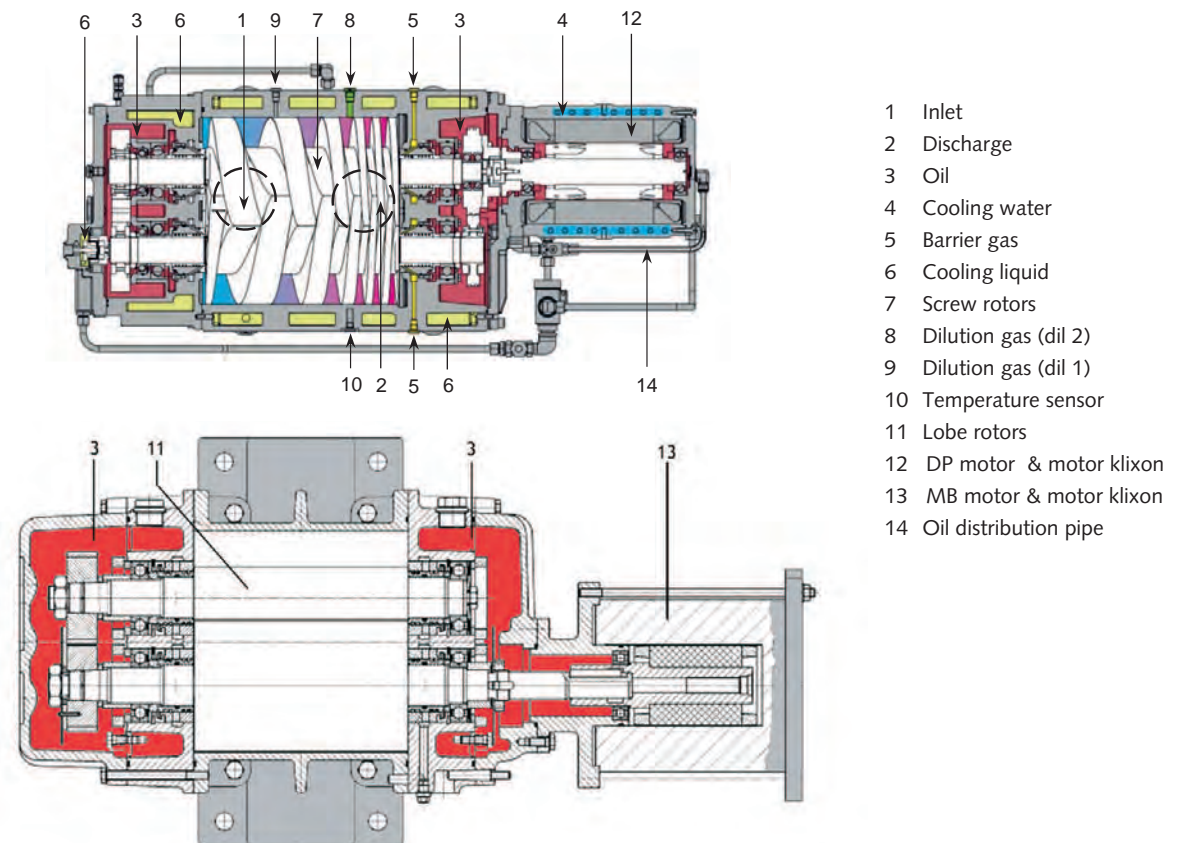

- 1 Inlet
- 2 Discharge
- 3 Oil
- 4 Cooling water
- 5 Barrier gas
- 6 Cooling liquid
- 7 Screw rotors
- 8 Dilution gas (dil 2)
- 9 Dilution gas (dil 1)
- 10 Temperature sensor
- 11 Lobe rotors
- 12 DP motor & motor klixon
- 13 MB motor & motor klixon
- 14 Oil distribution pipe

## Product description

### Use

The vacuum systems COBRA DS are designed for use in the field of microelectronics and similar industries.

They can be used to suck gases and gas mixtures.



#### WARNING

**When using toxic, inflammable and/ or explosive gases, make sure that the vacuum system corresponds in design to applicable local and national safety regulations and that all applicable safety measures are followed. All product-specific safety regulations must be observed.**

Solid particles must not get into the vacuum system. Procedural errors can result in the vacuum system sucking in a certain quantity of liquid. If the vacuum system has sucked in liquid, a short drying time is necessary at the end of the procedure.

The allowed maximum inlet gas temperature depends on the inlet pressure and the type of gas: the lower the inlet pressure (Pa), the higher the drawn gas temperature (T<sub>Gas</sub>) can be.

The following indicative values for air can be considered:

- Pa > 50 mbar, T<sub>Gas</sub> < 80°C
- Pa < 50 mbar, T<sub>Gas</sub> < 200°C

The vacuum system is intended for use in a potentially non-explosive environment.

Max. permissible number of startings per hour: 6.

The vacuum pump is thermally suitable for continuous operation at any pressure between atmospheric pressure and ultimate pressure.

The vacuum system is tight down to ultimate pressure.

## Operating principle

The vacuum systems COBRA DS standard version is a combination of one or more COBRA NS (DP 600) vacuum pumps with cooling water and nitrogen circuits and one or more WY (MB) rotary lobes vacuum pumps with a frequency inverter.

The gas conveying is done on two levels: one by the Roots WY vacuum pump and the other by one or two COBRA NS 600 C vacuum pumps working in parallel. The pressured gas is conveyed to the respective silencers.

Principle of the screw vacuum pump DP

The COBRA NS vacuum pumps work by the principle of screw pumps. Two parallel screws (7) rotate in opposite directions in the pump body. Entering gases are trapped between the flights of the screws and the pump body. The gases are conveyed by the rotation of the screws to the exhaust, where they are discharged.

The COBRA NS vacuum pumps are driven by water-cooled motors.

Principle of the lobe vacuum pump Roots MB

The WY rotary lobes vacuum pumps operate according to the approved principle of the Roots type machine. Operation is both simple and effective. Two lobes rotors (11) with identical profiles rotate in opposite directions within a casing. As they rotate, gas is drawn into the space between each rotor and the casing where it is trapped and by the rotation pushed out into the discharge. This action is repeated twice for each revolution of each rotor and therefore four times for each revolution of the drive shaft. There is no mechanical contact between rotors and cylinder. So no oil lubrication is required.

The WY rotary lobes vacuum pumps are driven by water-cooled motors.

Principle of the vacuum system COBRA DS

- 1) Start DP: During start-up, the COBRA NS (DP 600) starts first. If there are several pumps NS, DP1 starts first and then DP2 and DP3 starts after the delay of the timer "DP2 ON DELAY" is done (timer settable in the settings, normally at 1s).
- 2) Start MB: The WY Roots pump will start after the DP1 when the delay of the timer "MB ON DELAY" is done (timer settable in

the settings, normally at 30s). If there are several WY Roots, they start together.

- 3) Cold start timer: After the start-up, the WY Roots runs at low speed for heating-up. It runs normally when the delay of the timer "COLD START" is done (timer settable in the settings, normally at 1200s). The timer can be bypassed by pressing the "Start" button 5 seconds.
- 4) Ready for work: When the COBRA NS pump and the WY Roots pump are hot, the pump can normally work for the customer process.
- 5) Purge time: When the "Stop" button is pressed only one time, the "PURGE TIMER" starts. When the timer is done (timer settable in the settings, normally at 1800s), the pump switches off normally. This timer can be deactivated by the parameter "PURGE CYCLE = OFF" in the settings. The timer can be bypassed by pressing the "Stop" button 10 seconds.
- 6) Stop sequence: All the WY Roots pumps are firstly stopped and then all the COBRA NS vacuum pumps stop 60 seconds after. The timer can not be modified.

## Structure

The vacuum system COBRA DS is made of the following elements:

- a) One or more COBRA DP 600 C (DP1, DP2, DP3...) backing vacuum pumps with sensors
- b) Horizontal silencer mounted on each vacuum pump (standard)
- c) Vertical silencer installed behind each vacuum pump to collect condensates in an external tank. This silencer is water cooled (29 l/min) (option)
- d) Connection kit MB to DP. The kit contains different parts (solid pipes with belows and o-rings hold by claws and screws). Each kit depends on the pump configuration. If there are only one DP 600 and one WY Roots (DS 8161 for example), the connexion is directly made from the MB Roots to the DP 600.
- e) One or more WY 075 boosters (MB1, MB2...) rotary lobes vacuum pumps with sensors and frequency inverter.
- f) An electrical box mounted on the right or rear side of the MB booster with combined cables (powers and sensors) for each pump.
- g) An LCD controller.
- h) Nitrogen and water distributor if several pumps (DP and/ or MB) or options (vertical silencer) are used.
- i) Other special parts if the vacuum system is specially large extra (extra inlet or exhaust piping, special power cables rack).

All parts of the installation are mounted on a stable frame and are completely equipped with their pipes.

The electrical components are wired with an connection box.

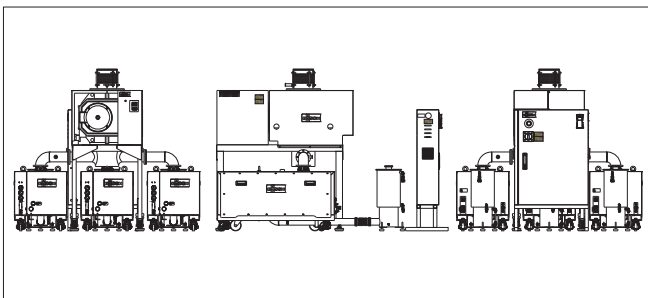

Combi DS 8163 B: one Roots WY 075 and one COBRA DP 600 C pump (Separate electrical box and vertical silencer (option)):

## Oil circulation

Since the complete operating principle works without contact, no oil circuit is needed in the work area.

## Cooling



WARNING

The cooling liquid system is active only when the DP vacuum pumps are in function. The cooling liquid circuit works on the axle of the motor.



WARNING

The cooling water system is always active. The cooling water flows continuously from the water distributor.

The vacuum system COBRA NS is cooled by

- the circuit of cooling liquid (mix of water and glycol) inside the water chambers (6) of cylinder and endplate of cylinder B-side An indirect circuit is made with a water pump mounted at the motor endplate. The flow of the cooling water is controlled by a flow switch FS 1. If the flow is under 1 l/min during a minimum time of 30 seconds, then the pump stops. The temperature switch TS 2 will give an emergency signal if the temperature of the cooling liquid is above 100°C.
- a cooling water circuit (4) in the cylinder and endplate of cylinder B-side. The cooling water flow is controlled by the thermostatic valve TR whose temperature sensor is assembled in the cylinder cover side A. The position of the thermostatic valve is leaded of factory with 3,5 (higher value will set hotter temperature into the cylinder). Normally setted at position 2,5.
- a direct cooling water circuit in the motors of COBRA NS vacuum pump. The cooling water flow is preset at 29 l/min at the factory and can be adjusted with valve CWV 1. The flow is controlled by flow switch FS 2. The cooling water circuit stabilizes the temperature of cooling liquid. When flow is too low a warning then an alarm signal is generated by flow switch FS 2 to the PLC. Status of the pump depends on the alarm function set by user (factory setting: EMO, pump stops after alarm condition).
- a direct cooling water circuit in the motors of WY rotary lobes vacuum pump. The cooling water flow is preset at 29 l/min at the factory and can be adjusted with valve CWV 2. The flow is controlled by flow switch FS 3. The cooling water circuit stabilizes the temperature of cooling liquid. When flow is too low a warning then an alarm signal is generated by flow switch FS 3 to the PLC. Status of the pump depends on the alarm function set by user (factory setting: EMO, pump stops after alarm condition).

### NOTE:

- The COBRA DS vacuum systems are generally dispatched with oil and cooling liquid already in the vacuum system but, without cooling water. Before vacuum system first startup, control the oil level and the cooling liquid level. In the event of absence of one or the other of these lubricants, please carry out the filling (please refer to the various chapters of filling). Do not forget to connect the cooling water supply before the first startup. Operation without these coolants can result in damage to the vacuum system.
- The CWM 1 and CWM 2 captors are serial connected. One alarm signal is generated for the both.

## Nitrogen system



WARNING

The nitrogen system is active only when the DP vacuum pumps are in function. The electrovalve is controlled by KDP.

The nitrogen system performs two main functions:

- nitrogen is used as dilution gas. It is injected in the middle hole (9) and is preset at 20 l/ min. It can be adjusted with valve DGR 1, depending on the application. But higher the dilution flow is, worse the base pressure will be. Nitrogen flow injected in the hole on cylinder endplate side (8) is preset at 40 l/ min and can be adjusted with valve DGR 2, depending on the application. When flow is too low a warning then an alarm signal is generated by flow

meter FME to the PLC. Status of the system depends on the alarm function set by user (factory setting: None, system continues running with an alarm). Dilution improves the screws functioning, especially when sucking corrosive gases.

- the nitrogen is used as sealing gas. The nitrogen is injected into the intermediate chamber (5) in the cover of the cylinder NS pump to achieve good closeness.
- the nitrogen can also be used as flushing gas. Depending on the application, flushing is recommended after every use to ensure troublefree operation of the vacuum system. The nitrogen is injected directly into the intake port. In the absence of nitrogen flushing can also be performed with the help of air.

## Optional functions/ Use of available accessories

The LCD controller processes the data of the sensors (see chapter "Communication with the equipment") as follows:

- temperature in the cylinder (option)
- Current DP and MB
- nitrogen flow rate
- cooling water flow rate
- oil temperature
- control of the cooling liquid flow
- cooling liquid temperature and flow
- exhaust pressure (option)

An horizontal silencer under the pump or a vertical silencer (option) at the exhaust reduces the noise of the vacuum system and collects any condensate.

The data process with the C.M.S. (Central Monitoring System) (accessory) has the same function as the LCD controller (see Operating Instructions of Central Monitoring System).

A temperature sensor PT100 (10) (option) mounted on the cylinder, measures the temperature inside the cylinder.

The safety valve (SV) prevents excessively high pressure in the expansion tank (EV), relief pressure: 6 bar (option).

A pressure switch (optional) with normally closed contact mounted in the expansion tank monitors the pressure of the cooling liquid. It must be connected in such a way that actuation causes the vacuum system to be switched off.

A leak-protection non-return valve (option) at the exhaust traps the condensate in the vacuum system when the vacuum system is switched off.

## On/ Off switch

The on/ off switch function is realised by the LCD. The vacuum pump is delivered with a circuit breaker.

# Safety

## Intended use

**DEFINITION:** To rule out any misunderstanding, the term "handling" of the vacuum system covers transport, storage, installation and operation of the vacuum system as well as effects on operating states and troubleshooting on the vacuum system.

The vacuum system is intended for industrial use. It may only be operated by qualified personnel.

The different application possibilities and limit values for operation described in "Product description" and "Installation requirements" must be observed by the manufacturer of the vacuum system into which the vacuum system is to be integrated and by users.

The need for personal safety regulations depends in principle on the type of use. The operator must provide the users with the necessary means and must inform his personnel about the dangers emanating from the processed product.

The operator of the vacuum system must observe the safety regulations and must train and instruct his personnel accordingly.

Local regulations regarding the motors and electric control elements must be observed when installing the vacuum system in potentially explosive environments.

The maintenance instructions must be followed and observed.

These installation and maintenance instructions must be read and understood before the vacuum system is used. If you have any doubts, contact your Busch representative.

## Safety information

The vacuum system is designed and manufactured in compliance with the latest technical standards and safety regulations. Nevertheless an element of residual risk remains.

Various safety instructions are to be found in this handbook and on the vacuum system. These instructions must be followed. You can recognise these instructions by the signal words DANGER, WARNING and CAUTION, which are defined as follows:



**DANGER**

Disregard of this safety instruction will always result in death, serious injuries or severe damage.



**WARNING**

Disregard of this safety instruction may result in death, serious injuries or severe damage.



**CAUTION**

Disregard of this safety instruction may result in minor or moderate injuries or damage.

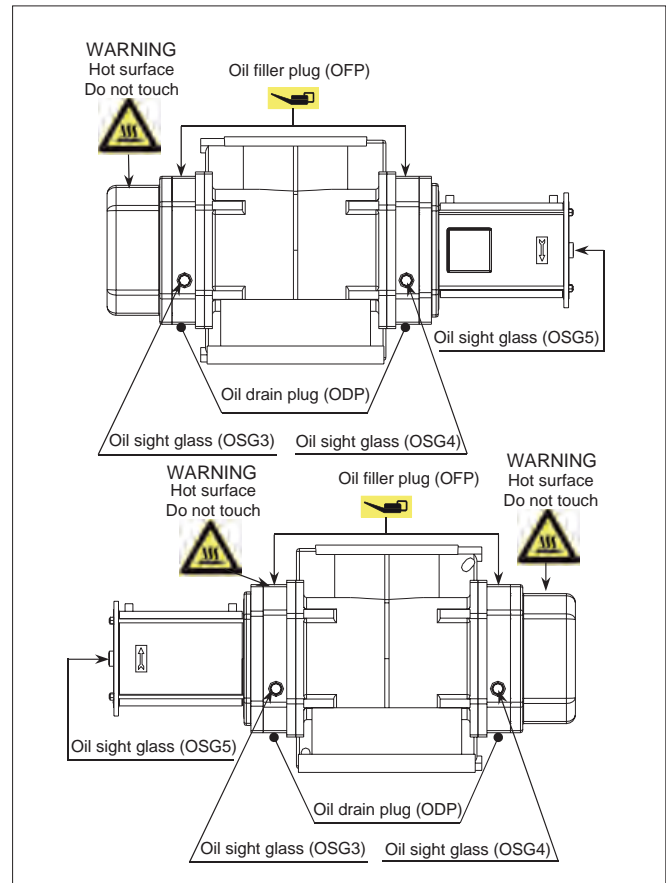
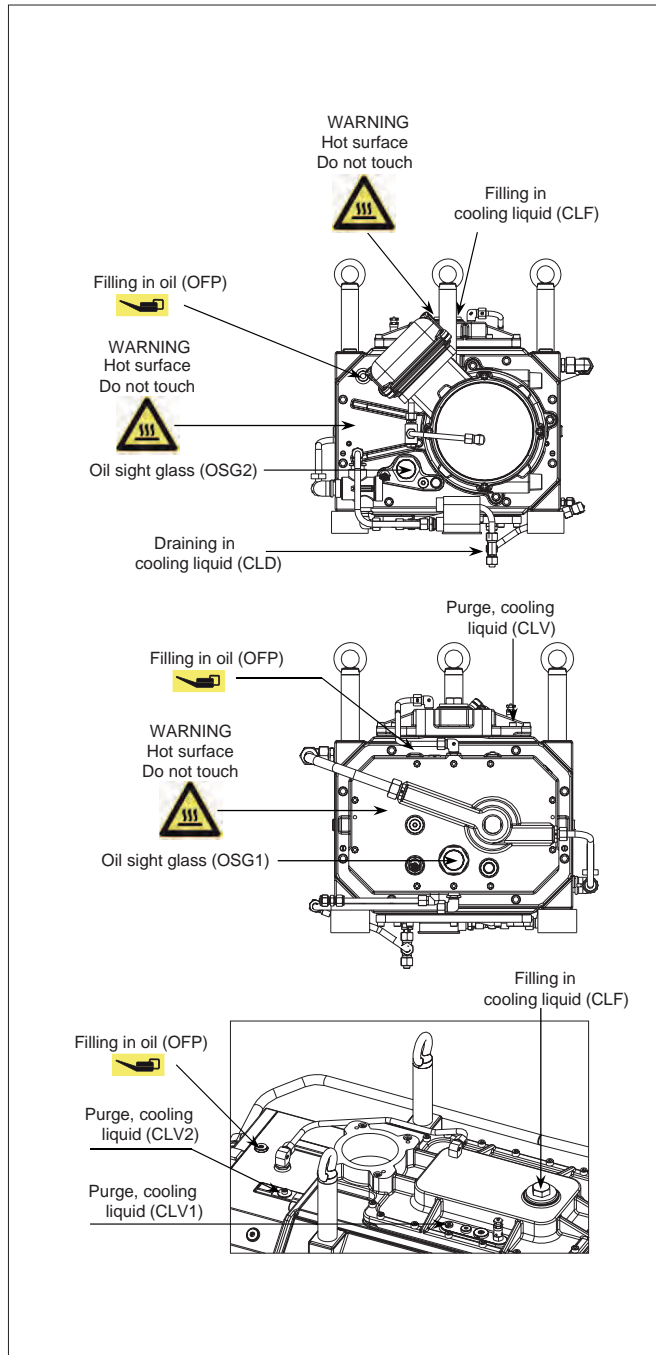

## Noise emission

Refer to the table "Technical data" for the permissible noise level in free field conditions according to EN ISO 2151.



The intensity of the noise of the vacuum system is higher within a certain area of the vacuum system.

Risk of hearing damage.

Users must wear ear protection when spending a longer period of time in the vicinity of a non-insulated vacuum system.

## Maintenance clearance

Before any maintenance action, ensure a maintenance clearance around the vacuum system of min. 610 [mm].

## Electrical safety

### Types of Electrical Work

The following are the four types of electrical work defined by the SEMI S2, latest version, guideline:

#### Type 1

Equipment is fully deenergized.

#### Type 2

Equipment is energized. Energized circuits are covered or insulated.

**NOTE :** Type 2 work includes tasks where the energized circuits are or can be measured by placing probes through suitable openings in the covers or insulators.

#### Type 3

Equipment is energized. Energized circuits are exposed and inadvertent contact with uninsulated energized parts is possible. Potential expo-

ures are no greater than 30 volts rms, 42.4 volts peak, 60 volts dc or 240 volt-amp in dry locations.

#### Type 4

Equipment is energized. Energized circuits are exposed and inadvertent contact with uninsulated energized parts is possible. Potential exposures are greater than 30 volts rms, 42.4 volts peak, 60 volts dc, or 240 volt-amp in dry locations. Potential exposures to radio-frequency currents, whether induced or via contact, exceed the limits in Table A5-1 of Appendix 5 (SEMI S2 guideline).

#### Lock Out/ Tag Out procedure (Type 1 of electrical work)

- Stop the pump with the remote control (press on STOP button during 10s)
- Press on emergency stop button
- Switch off the main disconnect switch
- Switch off the customer's power supply
- Switch off the water (inlet first, then outlet) and nitrogen quick connections
- Put the label or warning board "Maintenance processing" on or next to the pump

#### Safety Lockout procedure

- Take off the label or warning board "Maintenance processing"
- Check the cooling liquid and oil levels according to the chapters "Checking the oil level" and "Checking the cooling liquid level"
- Open the power box cover and check that the FDP1 thermal relay is on manual reset position
- Close the cover
- Switch on the main disconnect switch
- Release the emergency stop button
- Switch on the water (outlet first, then inlet) and nitrogen quick connections

Start the pump with the remote control (press on START button)

#### Emergency off circuit description

- The Emergency off circuit may be opened by pressing on emergency stop button, by opening the overload relay (s) FDP1, FDP2, FDP3, FDP4 or the temperature switch TS 6. If one of the elements fails, then the vacuum system will immediately stop. The PLC will remain energized to save the pump status.
- If the emergency stop button was pressed, check the start up of the pump then release this button to restart the pump. Press on Silence button for Reset, then Start button on the remote control, the pump will restart.
- If the FDP1 or FDP2, FDP3, FDP4 thermal protection is on, press on emergency stop button, switch off and padlock the main disconnect switch, switch off the customer's power supply (type 1 of electrical work). Open the power box cover and check the value on the FDP1 or FDP2, FDP3, FDP4 thermal relay(s) according to the settings indicated in the electrical schematics.
- If ok, check the wiring system from the terminal box motor to the KDP1 contactor. If ok, call the BUSCH Semicon service team in charge of the maintenance of the pumps.
- Before restarting the vacuum system, reactivate the FDP1 thermal relay by pressing on Reset. If this does not work, wait 60 seconds and start the operation again. Close the cover again. Switch on the main disconnect switch, then release the emergency stop button. Restart the vacuum system by pressing on Start button on the remote control. If the vacuum system does not start, press on emergency stop button, switch off and padlock the main disconnect switch, switch off the customer's power supply and put the label "maintenance processing". Call the BUSCH Semicon service team in charge of the maintenance of the pumps.
- If the external thermal protection B11 is engaged, check that the water flow shows 29 l/min on the flowmeter. If not, set the water

flow at 29 l/min according to the instruction (see chapter "Checking the cooling liquid flow"). Check the wiring system of the thermal protection by opening the side face (Type 3 of electrical work). Wait a few minutes for the cooling of the protection, then press on Start button to restart the vacuum system.

#### Safety interlock description

See "Interlock table".

#### Lock out/ Tag out for hydraulics and pneumatics

- ◆ Hydraulics: cooling water
- ◆ Pneumatics: nitrogen

#### Lock Out/ Tag Out procedure (Type 1 of electrical work)

- Stop the pump with the remote control (press on STOP button during 10s)
- Press on emergency stop button
- Switch off the main disconnect switch
- Switch off the customer's power supply
- Switch off the water (inlet first, then outlet) and nitrogen quick connections
- Put the label or warning board "Maintenance processing" on or next to the pump

The end user is responsible for providing energy isolation capabilities on the water and nitrogen

#### Interlock table

Interlock event	Sensor	Response	
Cooling liquid overtemperature	Temperature switch TS 2	Contactors open and remove power to motors	S
DP, MB motors overcurrent	Thermal overload relays EOCR (MB) Thermal overload relays EOCR (DP 1, 2 & 3)	Contactors open and remove power to motors. For DP, the security circuit is shut down then reload the thermal relay. For MB, the MB circuit is shut down then reload the thermal relay.	S
DP Motor overtemperature (t° > 150°C)	Temperature switch TS 6	Contactors open and remove power to motors. EMO: security circuit	S
MB Motor overtemperature (t° > 150°C)	Temperature switch TS 7	MB vacuum pump stops	S
Exhaust overpressure (option)	Overpressure sensor TS 5	Depends on alarm function set in the PLC for overpressure Set at factory: None ie. the pump continues running with alarm	S

DP, MB motors overcurrent	Current gauge EOCR	Depends on alarm function set in the PLC for overcurrent. Set at factory: General Stop ie. the contactors open and remove power to motors.  For DP overcurrent: EMO urgent switch off.  For MB overcurrent: all MB pumps stop.	S
Cylinder overtemperature	Temperature switch TS 3	Depends on alarm function set in the PLC for cylinder temperature. Set at factory: General Stop ie. the contactors open and remove power to motors	S
Cooling water flow low	Water flow switch FS 1/ FS 2	Depends on alarm function set in the PLC for water flow. Set at factory: General Stop ie. the contactors open and remove power to motors	S
Nitrogen flow to low	Nitrogen flowmeter FME	Depends on alarm function set in the PLC for nitrogen flow. Set at factory: General Stop ie. the vacuum system continues running with the alarm	S
Cooling liquid flow to low	Flow controller FCV	The contactors open and cut the engine supply after 30 seconds	S
Excessive oil temperature (t°>105°C)	Temperature switch TS 1	The contactors open and cut the engine supply after 120 seconds (changeable duration)	S

H= Hardware, S= Software

"X" is the number of the DP or MB vacuum pump

# Transportation

The vacuum systems COBRA DS are tested and checked in our factory before careful packing. Check the packaging for transport damage when the goods arrive. The vacuum system can withstand temperatures between  $-25^{\circ}\text{C}$  and  $+55^{\circ}\text{C}$  during transport.

## Handling

For handling of individual components look up the relevant Operating Instructions in the Appendix.

The vacuum system is supplied in wooden crates.

The ring bolts on the components are not designed to take the full weight of the vacuum system.

Depending on the dead weight and size of the vacuum system, use a forklift to move it on several pallets.

Or lift the vacuum system using slings and the appropriate lifting gear to move the vacuum system or remove the pallets.

Be sure to avoid strain on pipework or vacuum pumps when placing the slings.

## Transportation in packed state

The vacuum system is packed in wooden crates. It protects the vacuum system from damage in transit.

## Transportation in unpacked state

The vacuum system can be transported without the wooden crates with a lift truck or using slings and appropriate lifting gear which will take the full weight of the vacuum system.



CAUTION

Do not work, walk or stand under suspended loads.



CAUTION

Please check out the weight of the vacuum pump before lifting it up (see "Technical Data").

Use adequate lifting gear for this.

**NOTE:** The suspension eyes are located at about the center-of-gravity of the vacuum pumps. If the vacuum pumps are equipped with accessories that could influence the center-of-gravity, this must be taken into account when lifting and a belt must additionally be attached to a specific point.

### Lifting for DP 0600 C



- Fasten the hoist to the suspension eyes on the cylinder
- Use a hoist that is equipped with a hook and safety lock
- Lift the vacuum pump

If the vacuum pump is fastened to several pallets with fixing pins:

- ◆ Unscrew the fixing pins in the base frame



CAUTION

In the case of a vacuum system filled with oil, you ensure that the angle of inclination of the vacuum system at the time of rise does not exceed  $5^{\circ}$  compared to the horizontal. In the event of too important slope ( $> 5^{\circ}$ ), risk of oil leakage in the workspace.

Before each transport requiring a means of adapted lifting, control the slope of the vacuum system ( $< 5^{\circ}$ ).

The packaging material must be disposed of in accordance with local and national regulations.

This handbook is contained in the delivery package.

For future transportation :

- Seal all open connections with protective caps (to prevent penetration of dirt and water)
- Secure loose cables
- Protect from shock
- Drain all process and operating media
- Secure vacuum system firmly before transporting (e.g. bolt to several pallets)
- Use a lift truck to move and set the vacuum system down

## Storage

Take the following precautions before putting the vacuum system into storage:

- Clean and dry the vacuum system
- Where necessary use oil for conservation
- Before storing make absolutely sure that all parts are clean, drained and dry

See relevant documentation in the appendix for precise instructions on individual vacuum system components

## Removal of the vacuum system

Before starting a vacuum system that has been stored outside the building for a while, the vacuum system must be moved to a room with ambient temperature, where it should rest for a day.

## Preservation

If the vacuum system will be exposed to unfavourable ambient conditions (for example, aggressive environment, frequent temperature changes), begin immediately with preservation work on the vacuum system.

In the case of favourable ambient conditions, perform preservation work on the vacuum system if a storage period of more than three months is planned.

- Make sure that all openings are hermetically sealed; use adhesive tape to fasten loose parts (seal rings, flat seals, etc.).

**NOTE:** VCI is the abbreviation for "volatile corrosion inhibitor". The VCI molecule is an organic corrosion inhibitor in the vapour phase. Integrated in various carriers such as film, cardboard, paper, foam, liquid and powder, it protects the parts against corrosion as a result of its action in the vapour phase. However, VCI packaging can attack synthetic surfaces and surfaces of other elastomers. If in doubt, please contact your nearest distributor. VCI packaging provides several years of protection against corrosion, even under the harshest of conditions: overseas shipment, extended storage before use.

- Wrap the vacuum system in a VCI film
- Store the vacuum system
  - if possible, the vacuum system should be stored in its original packaging,
  - indoors,

- dry,
- in a dust-free and
- vibration-free room

### Start-up of the vacuum system after storage:

- Make sure that all protective elements, stoppers or adhesive tapes attached before preservation have been removed
- Switch on the vacuum system in the sequence described in the chapter "Installation and start-up"

## Installation and start-up

It is important for operating safety to observe the instructions when installing the vacuum system. Installation must be carried out by qualified technicians.

### Necessary installation instructions



CAUTION

If the necessary installation instructions are not followed and particularly in the case of inadequate cooling:

Risk of damage to and total destruction of the vacuum system and its components!

Risk of personal injury!

The necessary installation instructions must be followed.

- Make sure that the integration of the vacuum pumps in its new environment complies with the safety regulations according to the Machinery Directive 2006/42/EC (regarding the responsibility of the manufacturer of the vacuum system in which the vacuum pumps are to be integrated, see information in the EU-Declaration of Conformity).



WARNING

**Local regulations regarding the motors and electric control elements must be observed when installing the vacuum system in potentially explosive environments. Make sure before start-up that all safety measures have been followed.**

### Installation site and installation

- Make sure that the environment of the vacuum system is not potentially explosive
- Make sure that the following ambient conditions are fulfilled:
  - Ambient temperature: 0 ... 40 °C (32 ... 104 °F)
  - Ambient pressure: atmosphere
  - Humidity range: 20 to 95%
  - Altitude: up to 1000 m
- Make sure that the cooling water fulfills the following requirements:
  - Temperature: 10 - 20 °C
  - Water pressure: 2 - 5 bar (relative)
  - Water hardness: < 5° dGH

**NOTE:** 1° (german degree = 1° dGH) = 1,78° (french degree) = 1,25 e (english degree) = 17,9 mg/kg CaCO<sub>3</sub> (american hardness)

- Approximate flow rate: 29 l/ min for the standard version (hot vacuum system)
- Approximate flow rate: 29 l/ min for cooling DP and MB motors
- Approximate flow rate: 29 l/ min for cooling vertical silencers (option)
- Make sure that the cooling water is neutral and clean
- Make sure that the cooling water outlet is unpressurised
- Make sure that the nitrogen fulfills the following requirements:
  - Overpressure: 1,5 bar
  - Approximate flow rate: 0 - 200 l/ min

- Make sure that the ambient conditions correspond to the protection class of the motor (according to nameplate)
- Make sure that the vacuum system is placed on or fastened to a horizontal surface
- Make sure that the vacuum system is level
- Make sure that the vacuum system is at least 1 m away from any wall to ensure good cooling
- Make sure that the vacuum system is easily accessible and that the selected installation site fulfills the requirements for assembly/ dismantling
- Make sure that no temperature-sensitive parts (for example, of plastic, wood, cardboard, paper, electronic parts) come into contact with the hot surfaces of the vacuum system
- Make sure that the installation site or assembly area is ventilated in such a way that adequate cooling of the vacuum system is ensured



CAUTION

The surface temperature of the vacuum system can exceed 50°C when the vacuum system is in operation.

Danger of burns!

- Make sure that no-one can touch the vacuum system accidentally. If necessary, attach safeguard
- Make sure that the oil sight glasses are easily accessible

If oil changes are to be made on site:

- ◆ Make sure that the oil drain and oil filler are easily accessible

### Unpacking



DANGER

**Danger of vacuum system falling or tipping over! The weight of the vacuum system can kill a person or cause severe crushing.**

The ring bolts on the components are not designed to take the full weight of the vacuum system.

Depending on the dead weight and size of the vacuum system, use a forklift to move it on several pallets.

Or lift the vacuum system using slings and the appropriate lifting gear to move the vacuum system or remove the pallets.

Be sure to avoid strain on pipework or vacuum pumps when placing the slings.

Unpacking of vacuum system:

- Unpack the vacuum system as near the installation site as possible.
- Check scope of delivery for completeness.
- Check the vacuum system for damage.
- Only remove the vacuum system from pallets at the installation site. Observe the above safety precautions when doing so.
- Dispose of packing material as required by current regulations.

### Mounting



WARNING

**The vacuum system can be damaged by foreign matter in the pipelines!**

- Remove all foreign matter (welding beads, swarf etc.) from the pipelines!

This may be done by flushing or blowing through pipelines.

The installer must ensure that the pipework at the inlet is clean.

- Set the vacuum system on as level, horizontal surface.



- Leave enough space (min. 1,5 m) around the vacuum system for maintenance work.
- If necessary anchor the vacuum system base frame to the floor
- Reception and unpacking of the crates
- Oil filling in the Roots MB vacuum pumps
- Oil filling in the DP vacuum pumps
- Glycol filling in the DP vacuum pumps
- Set, fix and connect the Roots MB assembly (connection with the inlet of the DS vacuum pump)
- Install the piping bows on the DP/ MB vacuum pumps and the troughs on the MB vacuum pump
- Install the sensor wires and place the cables in the trough (power, N2 solenoid valve, sensors) (connection with power supply)
- Set and fix the H2O and N2 distributor (connection with the H2O and N2 supply)
- Cable and connect the MB Roots (power, sensors, H2O and N2)
- Set and fix the DP pumps and connect the flexible piping to the Roots MB (connection with the DS group)
- Connect the pumps DP (power, N2 solenoid valve, sensors)
- Connect the LCD control and switch the main contactor
- Flow and H2O alarm adjustment, Danfoss
- Start-up of the vacuum system (Start)
- Flow and N2 alarm adjustment and final adjustment



#### WARNING

The vacuum system can be damaged by tensile or compressive stresses on pipe connections!

- If stresses could occur, use compensators to connect pipes!



#### WARNING

The vacuum system can be damaged by condensate!

- Fit traps to inlet and discharge sided pipes to prevent condensate getting into vacuum pumps!

### Inlet connection

- Make sure that the protection that was attached to prevent penetration of particles during transport has been removed before the vacuum system is connected to the vacuum line



#### CAUTION

Do not put hands into the inlet aperture.

Risk of body damage!



#### CAUTION

The intake of liquids or solid particles can lead to the destruction of the vacuum system

If the sucked gas contains dusts or solid foreign bodies:

- ◆ Make sure that a filter or protective grating is installed at the extraction point
- Make sure that the nominal diameter of the intake line is at least equal to the diameter of the intake flange of the vacuum system to prevent a drop in the performance of the vacuum system in the case of a smaller cross-section
- Make sure that the vacuum system is connected with leakproof lines



#### CAUTION

When the intake lines have been connected, make sure that the system does not leak. Leakages of dangerous substances must be prevented!

- Make sure that the intake lines are equipped with a shut-off device upstream of the intake flange so that the flow of sucked gas can be stopped
- Make sure that the intake lines do not exercise any force on the intake flange. Mount bellows if necessary
- The inlet flange has the following dimension:
  - DN 250 ISO-K for the Roots WY 075 inlet (DS 8163, 8264)
  - DN 100 ISO-K for the COBRA DP 600 C inlet (inlet backing vacuum pump)

In the case of long intake lines the line cross-section should be larger than the intake flange to prevent a drop in the performance of the vacuum system. If you have any doubts, contact your Busch representative.

### Discharge connection



#### CAUTION

Do not put hands into the outlet aperture.

Risk of body damage!

The following instructions for connection to the discharge only apply if the sucked gas is discharged by the vacuum system into a suitable environment.

- Make sure that the protection that was attached to prevent penetration of particles during transport has been removed before the vacuum system is connected to the vacuum line
- Make sure that the nominal diameter of the exhaust line is at least equal to the diameter of the exhaust flange of the vacuum system to prevent a drop in the performance of the vacuum system in the case of a smaller cross-section

Make sure that the vacuum system is connected with leakproof lines



#### CAUTION

When the discharge lines have been connected, make sure that the vacuum system does not leak. Leakages of dangerous substances must be prevented!

- Make sure that the discharge lines are equipped with a shut-off device upstream of the intake flange so that the flow of sucked gas can be stopped
- Make sure that no shut-off devices are mounted in the discharge line
- Make sure that the discharge lines do not exercise any force on the intake flange. Mount bellows if necessary
- The discharge flange has the following dimension:
  - DN 63 ISO-K for each backing vacuum pump DP 600

In the case of long discharge lines, the line cross-section should be larger than the discharge flange to prevent a drop in the performance of the vacuum system. If you have any doubts, contact your Busch representative.

### Cooling water connection

The cooling water is generally connected with a hose (leakproof against oxygen).

- Connect the cooling water hose to the vacuum system distributor
- Connect the distributor to the cooling water supply

The cooling water outlet must be unpressurised.

Connection diameter: 3/8 NPT to reach 3-5 bar

- Set the waterflow at 23 l/min (CWM 1 and CWM 2) and set the Danfoss at the wished value (process)

## Nitrogen connection

The nitrogen is generally connected with a pipe (leakproof against oxygen).

- Connect the nitrogen pipe to the vacuum system distributor
- Connect the distributor to the nitrogen supply

Connection diameter: 1/4 NPT to reach 1.5 bar (≈3 bar)

## Electrical connection/ Checks



### WARNING

**Danger from electric shock! Electric shock can cause death and may damage the vacuum system.**

- Make sure that the regulations of the Electromagnetic Compatibility Directive 2014/30/EU as well as standard EN norms, safety directives and especially local and national regulations are observed (this is the responsibility of the manufacturer of the vacuum system into which the vacuum system is integrated according to the EU-Declaration of Conformity)
- Make sure that the main power supply corresponds to the data in the technical datas of the vacuum system
- Make sure that an overload cut-out according to EN 60204-1 is provided for the motor
- Make sure that the drive of the vacuum system is not disturbed by any electric or electromagnetic interferences. If you have any doubts, contact your Busch representative



### CAUTION

**Overvoltage damages the vacuum system!**

- Check permissible primary voltage next to the power connection!
- Connect the supply voltage leads on the main contactor.



### CAUTION

**Incorrect rotation of drive motors can seriously damage vacuum pumps!**

If the direction is wrong, an error message appears on the LCD: reverse two connection phase poles!

## Electrical connection

The vacuum system is build with voltage from 208 to 480 Volts.



### WARNING

**Risk of electrocution, risk of damage.**

**Electrical installation must be performed by a suitably qualified electrician who knows and follows the following regulations:**

- IEC 364 or CENELEC HD 384 or DIN VDE 0100,
- IEC Report 664 or DIN VDE 0110,
- VBG 4 or corresponding national regulations on accident prevention



### CAUTION

**The circuit diagrams described below conform to the standard. Other circuit diagrams might be used. This depends on the particular order and the market.**

**Risk of damage to the motors!**

**Check the connection of the motors inside the terminal box according to the circuit diagram.**

**Motor of screw pump DP 0600 C is connected at factory.**

## Procedure to connect the inline power cable

- Pass the cable through the inline power stuffing box



- Unscrew completely the ground phases screws
- Connect the ground wire to ground phase
- Unscrew completely the first connector on the main contactor

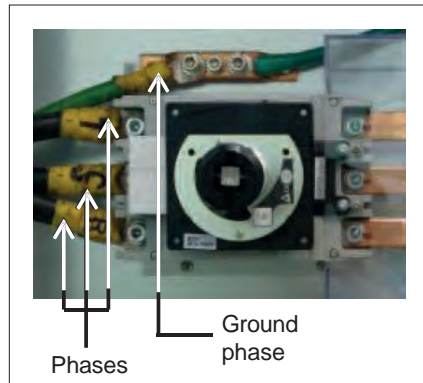

- Place the first phase wire and screw it completely, tight at 15 Nm
- Repeat for the other two phases



### CAUTION

**If the vacuum system is operated with a motor that turns in the wrong direction, it can be destroyed, even if this is the case for only a short moment.**

**Make sure that the vacuum system is connected correctly before switching it on.**

- If message "rotation sense false" appears, exchange two phases.
- Switch on the vacuum pump for a short period of time
- Make sure that the vacuum system aspirates

## Controls/ Function

Once start-up is complete the vacuum system need only to be switched on, in order to perform its job.

No further control is necessary during normal operation.

The unit is designed for continuous operation.

The vacuum system is controlled according to the programm flow chart.



### WARNING

**Insufficient operator familiarity with indication and control elements may result in damage to the vacuum system!**

Operators must be familiar with the controls. This will ensure smooth operation.

## Equipment connections (with options)

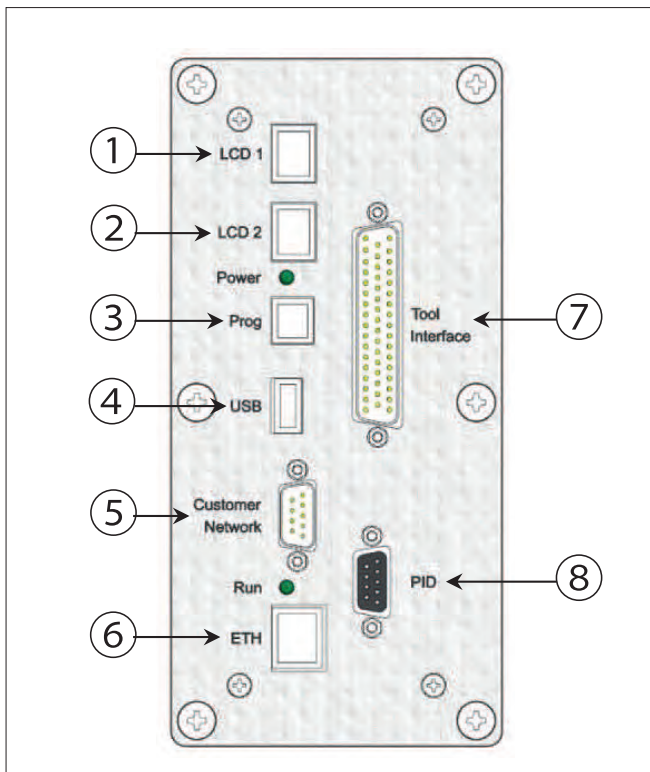

1	LCD serial wiring (RJ45), LCD 1
2	LCD serial wiring (RJ45), LCD 2
3	PC serial wiring (9 poles) (option)
4	USB connection
5	Customer network, Communication modbus RTU RS 232
6	Ethernet network connection (Busch Monitoring System) (option)
7	Interface connection (50 poles) (option)
8	PID interface (9 poles) (option)

The information concerning the use of the Busch PLC and the Busch LCD can be found in the Operation and Maintenance Instructions (Art-No. 0870758077).

## Connection of the lines/ pipes

- Connect the intake lines
- Connect the discharge lines
- Make sure that all caps, safeguards and similar covers are mounted
- Make sure that the inlet and outlet for the cooling air are not covered or closed and that the flow of cooling air is not impaired in any way

## Filling in cooling liquid

The COBRA DS vacuum systems are generally dispatched with cooling liquid in the vacuum pump (It depends on the way of shipping). Before vacuum system first startup, control the cooling liquid level. In the event of absence of this lubricant, please carry out the filling (see the chapter "Cooling liquid types" for information on the recommended cooling liquids).



### CAUTION

Do not run the vacuum system without cooling liquid!

- Prepare the quantity of cooling liquid specified in the table "Cooling liquid quantity"

**NOTE:** The quantity of cooling liquid specified in the installation handbook is of informative nature only. Respect the procedure of filling the cooling liquid.

- Open/ unscrew filler cap (CLF) of cooling liquid on cylinder upper plate
- Open/ unscrew purge cap (CLV) on cylinder upper plate and purge cap (CLV) on cylinder endplate B-side
- Fill in by filler hole until cooling liquid flows by purge cap on cylinder endplate B-side (gears)
- Stop filling in cooling liquid
- Close the purge cap on cylinder endplate B-side
- Fill in again by filler hole until cooling liquid flows by purge cap of cylinder upper plate
- Close the cap of cylinder upper plate
- Screw on the filler cap for the cooling liquid again
- If liquid has run on to the outside surfaces of the vacuum system, wipe it off
- Start the vacuum system

If the intake line is equipped with a shut-off device:

- ◆ Close the shut-off device

If the intake line is not equipped with a shut-off device:

- ◆ Place a rubber plate on the intake flange
- Let the vacuum system run for a few minutes
- Stop the vacuum system and wait a few minutes
- Unscrew purge cap on cylinder upper plate
- Control that cooling liquid level is just under cylinder upper plate

In case cooling liquid level is below required level:

- ◆ Fill in more cooling liquid

If the intake line is equipped with a shut-off device:

- ◆ Open the shut-off device

If the intake line is not equipped with a shut-off device:

- Remove the rubber plate from the intake flange and connect the intake line to the intake flange

## Checking the direct cooling

The flow of the cooling water is checked by the flow switch FS 2. The flowmeter must be connected in such a way that switching-on leads to an alarm and stopping of the vacuum system when the flow drops below 28 l/min.

## Checking the nitrogen

The flow of the cooling water is checked by the flowmeter FME. The flowmeter must be connected in such a way that switching-on leads to an alarm. The alarm limit can be adjusted depending on the type of process.

## Oil filling

The COBRA DS vacuum systems are generally dispatched without oil in the vacuum system (It depends on the way of shipping). Before vacuum system first startup, control the oil level. In the event of absence of this lubricant, please carry out the filling (see the chapter "Oil types" for information on the recommended oils).

### COBRA NS (DP) vacuum pump

- Prepare the quantity of oil specified in the table "Oil quantity"

**NOTE:** The quantity of oil specified in the installation handbook is of informative nature only. Check the oil level with the help of the various oil sight glasses (OSG 1, OSG 2) on the vacuum pump.



#### CAUTION

Before you change the type of oil, make sure that the new type is compatible with the old type. If necessary, flush the vacuum pump.

- Unscrew the oil filler cap (OFP)
- Fill in oil

### Oil level, pump not operating

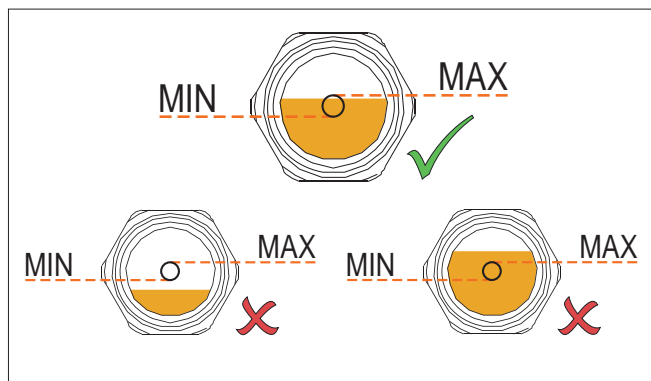

- Make sure that the oil level is in the target circle of the oil sight glasses (OSG 1 and OSG 2)
- Make sure that the seals of the oil filler cap are not damaged. Replace them if necessary
- Screw on the oil filler cap hermetically tight

### WY (MB) rotary lobes vacuum pump

- Prepare the quantity of oil specified in the table "Oil quantity"

**NOTE:** The quantity of oil specified in the installation handbook is of informative nature only. Check the oil level with the help of the various oil sight glasses (OSG 3, OSG 4, OSG 5) on the vacuum pump.



#### CAUTION

Before you change the type of oil, make sure that the new type is compatible with the old type. If necessary, flush the vacuum pump.

- Unscrew the oil filler cap (OFP)
- Fill in oil

## Oil level, pump not operating

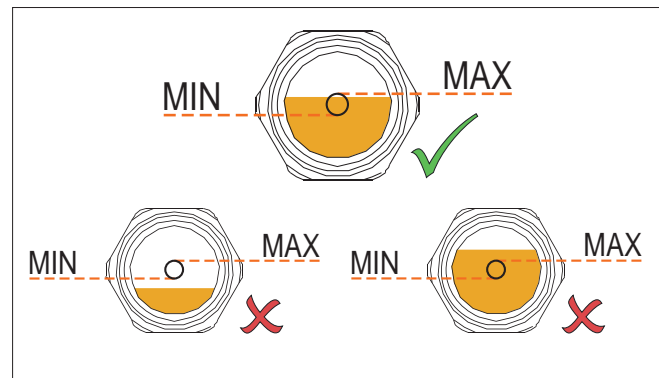

- Make sure that the oil level lies in the target circle of the oil sight glasses
- Make sure that the seals of the oil filler cap are not damaged. Replace them if necessary
- Screw on the oil filler cap hermetically tight

### COBRA DS vacuum system

**NOTE:** It is easier to switch on the vacuum pump with cold oil when the intake line is not closed or when the intake flange is not covered by a rubber plate.

- Start the vacuum system

If the intake line is equipped with a shut-off device:

- ◆ Close the shut-off device

If the intake line is not equipped with a shut-off device:

- ◆ Place a rubber plate on the intake flange
- Let the vacuum system run for a few minutes
- Stop the vacuum system and wait a few minutes

### COBRA NS (DP) vacuum pump

- Make sure that the oil level still lies in the target circle of of the oil sight glasses

If the oil level is below the target circle:

- ◆ Fill in more oil

If the intake line is equipped with a shut-off device:

- ◆ Open the shut-off device

If the intake line is not equipped with a shut-off device:

- ◆ Remove the rubber plate from the intake flange and connect the intake line to the intake flange

### WY (MB) rotary lobes vacuum pump

- Make sure that the oil level still lies in the target circle of the oil sight glasses

If the oil level is below the target circle:

- ◆ Fill in more oil

If the intake line is equipped with a shut-off device:

- ◆ Open the shut-off device

If the intake line is not equipped with a shut-off device:

- ◆ Remove the rubber plate from the intake flange and connect the intake line to the intake flange



#### CAUTION

In the case of a vacuum pump filled with oil, you ensure that the angle of inclination of the vacuum system at the time of rise does not exceed 5° compared to the horizontal. In the event of too important slope (> 5°), risk of oil leakage in the workspace.

- Before each transport requiring a means of adapted lifting, control the slope of the vacuum system ( $< 5^\circ$ ).



#### CAUTION

The vacuum system must remain in a horizontal position when it has been filled with oil.

## Recommendations on operation

### Application



#### WARNING

The vacuum system is designed for use under the conditions specified here.

**If these conditions are not met, there is a risk of damage to or total destruction of the vacuum system and its components!**

The vacuum system may only be switched on under the specified conditions.

The COBRA DS vacuum pumps are designed for use in the field of microelectronics and similar industries.

They can be used to suck gases and gas mixtures.



#### WARNING

**When using toxic, inflammable and/ or explosive gases, make sure that the vacuum system corresponds in design to applicable local and national safety regulations and that all applicable safety measures are followed.**

**All product-specific safety regulations must be observed.**

Solid particles must not get into the vacuum system. Procedural errors can result in the vacuum system sucking in a certain quantity of liquid. If the vacuum system has sucked in liquid, a short drying time is necessary at the end of the procedure

The allowed maximum inlet gas temperature depends on the inlet pressure and the type of gas: the lower the inlet pressure (Pa), the higher the drawn gas temperature (T<sub>Gas</sub>) can be.

The following indicative values for air can be considered:

- Pa > 50 mbar, T<sub>Gas</sub> < 80°C
- Pa < 50 mbar, T<sub>Gas</sub> < 200°C

The vacuum system is intended for use in a potentially non-explosive environment.

Max. permissible number of startings per hour: 6.

As far as temperature is concerned, the vacuum system is suitable for continuous duty at any pressure between atmosphere and ultimate pressure.

The vacuum system is tight down to ultimate pressure.



#### CAUTION

The surface temperature of the vacuum system can exceed 50 °C when the vacuum system is in operation.

Danger of burns!

The vacuum system may not be touched when it is in operation. If touching the vacuum system is unavoidable, wait until the surface temperature has cooled down or wear protective gloves.



#### CAUTION

The intensity of the noise of the vacuum system is higher within a certain area of the vacuum system.

Risk of hearing damage.

Users must wear ear protection when spending a longer period of time in the vicinity of a non-insulated vacuum system.



#### CAUTION

The COBRA DS vacuum pumps can be delivered without oil.

Operation without oil will result in damage to the vacuum system!

The vacuum system must remain in a horizontal position when it has been filled with oil.



#### CAUTION

The COBRA DS vacuum pumps can be delivered without cooling liquid.

Operation without cooling liquid will result in damage to the vacuum system!



#### CAUTION

The cooling water flow, which is checked by the flow switch FS 2, must be at least 28 l/min.

- Make sure that all caps, safeguards and similar covers are mounted
- Make sure that the safeguards are switched on
- Make sure that the inlet and outlet for the cooling air are not covered or closed and that the flow of cooling air is not impaired in any way
- Make sure that the vacuum system does not leak. Leakages of dangerous substances must be prevented
- Make sure that the "Necessary installation instructions" are followed and especially that adequate cooling is ensured

The following must be noted when the vacuum system is shut down for a longer period of time:



#### CAUTION

If there is a risk of frost, all the cooling water must be drained out of the vacuum system if the vacuum system is shut down for a longer period of time!

- Drain the cooling liquid
  - ◆ Open the drain cap (CLD) under the vacuum pump
  - ◆ Unscrew the filler cap for the cooling liquid and the purge cap on B-side (gearings)
  - ◆ Drain the cooling liquid completely
  - ◆ Screw on the filler cap for the cooling liquid again
  - ◆ Screw on the drain cap (CLD) under the vacuum pump
  - ◆ Collect the cooling liquid and recycle it or dispose of it according to local or national regulations
- Drain the cooling water
  - ◆ Open the CWV 1 and CWV 2 valves and Danfoss to 1
  - ◆ Pull off the connections for the inlet and outlet of the cooling water
  - ◆ Drain the cooling water completely

- ◆ If necessary, drain the cooling water with the help of compressed air to prevent any risk of frost or corrosion

**NOTE:** When the vacuum system has not been in operation for a few days or when a sticky substance has been sucked, it is possible that the two screw rotors of the NS (DP) vacuum pump will stick to each other. Screw open the access cover to the screw rotors. Loosen the rotors from each other with the help of an Allen key by turning them in clockwise direction by hand.

## Start-up of the vacuum system



### WARNING

The vacuum system may be destroyed if low on operating material!

- Check the gear oil level on the vacuum pumps (oil sight glass), see also relevant operating instructions!
- Fill or top up with gear oil as necessary.
- Inlet and delivery side of vacuum system are correctly piped
- Inlet and delivery water of vacuum system are correctly piped
- Compressed air is available for the valve controls
- Supply voltage is switched on
- The vacuum system is switched on by the LCD or interface box.

## Monitoring equipment

The vacuum system drive motors are safeguarded by a motor protection circuit. If an overload occurs the vacuum system is shut down.

For DP pumps: the manually set thermal relays shut down the circuit when alarm occurs. It needs to be reloaded in the electrical box for re-start. The current sensor and the temperature motor sensor shut down the power supply of the pumping group when alarm occurs.

For MB pumps: the manually set thermal relays shut down all the MB pumps when alarm occurs. It needs to be reloaded in the electrical box for restart. The current sensor, the temperature sensor and the frequency inverter shut down all the MB pumps when alarm occurs.



### WARNING

Risk of vacuum system deterioration by excessing temperature!

## Switching the vacuum system on/ off

### First start-up of the vacuum system

- In REMOTE mode, the start/ stop drive of the vacuum system passes through the main machine interface of the vacuum system (the one connected to TOOL).
- In LOCAL mode, the start/ stop drive of the COMBI COBRA DS is done independently.
- Make sure that the "Necessary installation instructions" are followed
- Make sure that the cooling water flow is set correctly
- The cooling water flow is factory set on 29 l/min and can be adjusted at the regulating cock CWV 1 and CWV 2. This water circuit is used to cool the motor of the DP and MB vacuum pumps and the cylinder covers A- and B-side of the MB vacuum pump. It cools also the cylinder and cylinder endplate B-side when temperature of cooling liquid is above 50°C.
- Make sure that the nitrogen flow is set correctly
- Nitrogen flow injected in the middle hole (9) is preset at 20 l/min and can be adjusted with valve DGR 1. Nitrogen flow injected in the hole on cylinder endplate side (8) is preset at 40 l/min and can be adjusted with valve DGR 2.
- Switch on the vacuum system
- Make sure that the vacuum system does not leak

## Switching the vacuum system off

- In REMOTE mode, the start/ stop drive of the vacuum system passes through the main machine interface of the vacuum system (the one connected to TOOL).
- in LOCAL mode, the start/ stop drive of the COMBI COBRA DS is done independently.

If the vacuum system is equipped with a solenoid gate valve at the intake:

- ◆ Close the solenoid gate valve
- Switch off the vacuum system
- Shut off the nitrogen supply
- Shut off the cooling water supply

If the vacuum system is equipped with a solenoid gate valve (customer option) in the cooling water circuit:

- ◆ Close the solenoid gate valve
- Make sure that the vacuum system is currentless

## Description of the Load Lock operation mode:

- LL Mode = Off
  - ◆ The mode « Load Lock » is de-activated, the module DP and the module MB, when present, operate constantly at their maximum frequency of rotation.

**NOTE:** the parameters « DP (or MB) Current Level », « Time Before » and « DP Idle » are idle.



### CAUTION

LL Mode = Off is not recommended for Load Lock cyclic pumping due to the current load and the mechanical stress with full speed.

- LL Mode = Auto
  - ◆ The mode Load Lock is activated and de-activated according to the current load taken in by the module DP (or MB). The current threshold is adjustable using the parameters « DP/MB Current Level ». When the current level exceeds the threshold, the modules DP and MB accelerate to their maximum frequency of rotation. When the current level drops below the threshold, a time delay which is adjustable in its duration using the parameter « Time Before », will start. As soon as the time delay's duration has elapsed, the modules DP and MB slow down to their minimum frequency of rotation.

### NOTE:

- If the parameter « DP Idle » is configured to « Disable », the module DP runs constantly at maximum frequency of rotation.
- If the module is not controlled by a frequency inverter, module MB is started if the current level exceeds the threshold and is stopped if the current level drops below the threshold and if the time delay's duration has elapsed.

- LL Mode = External
  - ◆ The Load Lock mode is activated and de-activated depending on the digital input status « Remote Process On » which is available on the tool interface. When the input changes to status 1, the modules DP and MB accelerate to their maximum frequency of rotation. When the input changes to status 0, the modules DP and MB slow down to their minimum frequency of rotation.

### NOTE:

- When the parameter « DP Idle » is configured to « Disable », the module DP runs constantly at the maximum frequency of rotation.
- The parameters « DP (or MB) Current Level » and « Time Before » are idle.
- Refer to chapter « Description of MENU 08 TOOL INTERFACE » for the configuration of the input « Remote Process On ».
- If the module MB is not controlled by a frequency inverter, module MB is started if the input changes to status 1 and is stopped if the input changes to status 0.



### CAUTION

The mode « Load Lock » will not work when:

- The warming up cycle has not finished.
- The mode maintenance is activated.



### CAUTION

- Be careful to set « Current level » and « Time Before » parameters regarding process cycle time and chamber size to be sure module MB is stopped or running idle speed before opening inlet valve.
- Be careful to change input status to 0 before opening inlet valve.

# Standard operational time chart

Signal control mode (Select LL mode = EXTERN)

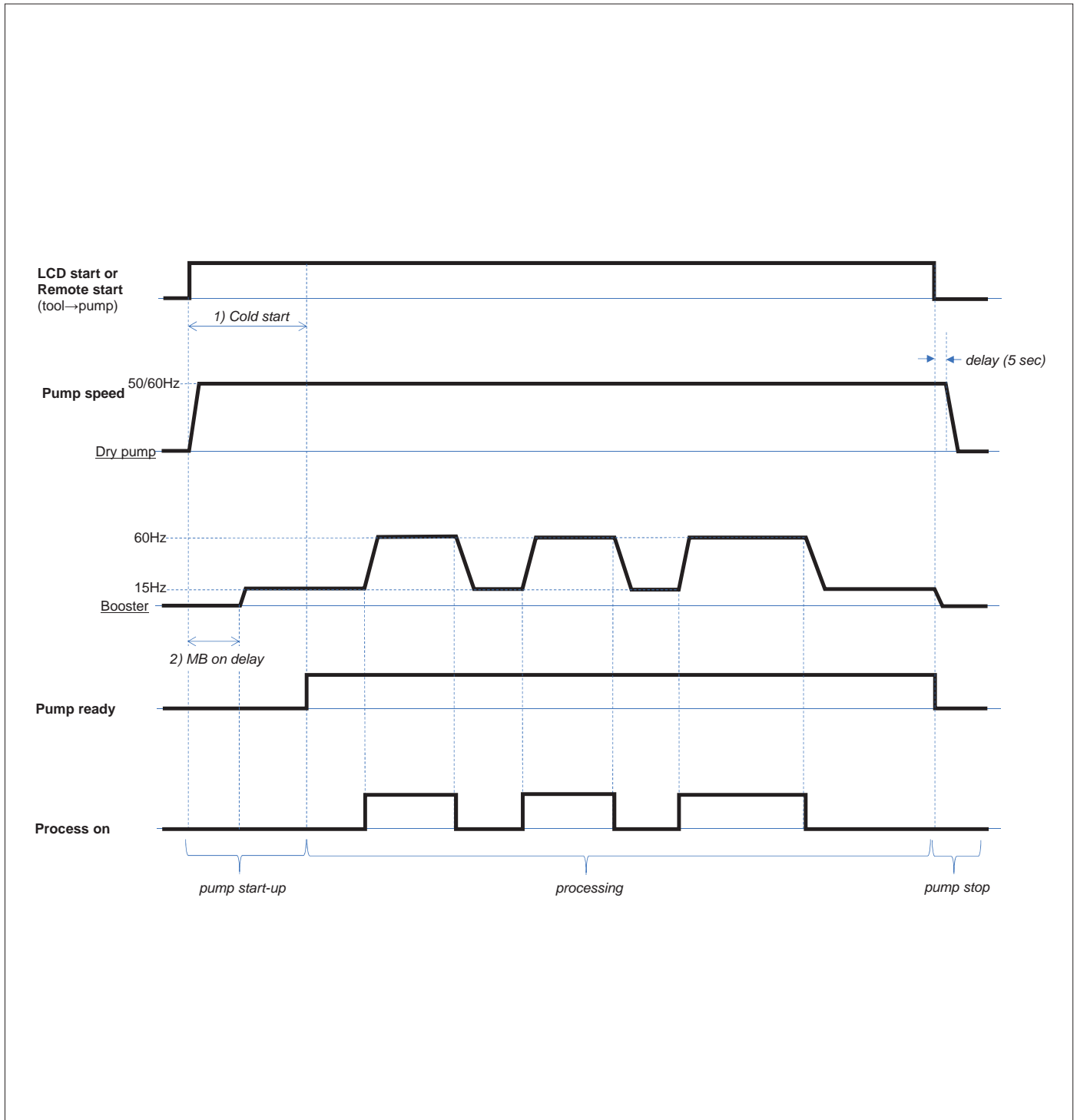



# Current control mode (Select LL mode = AUTO)

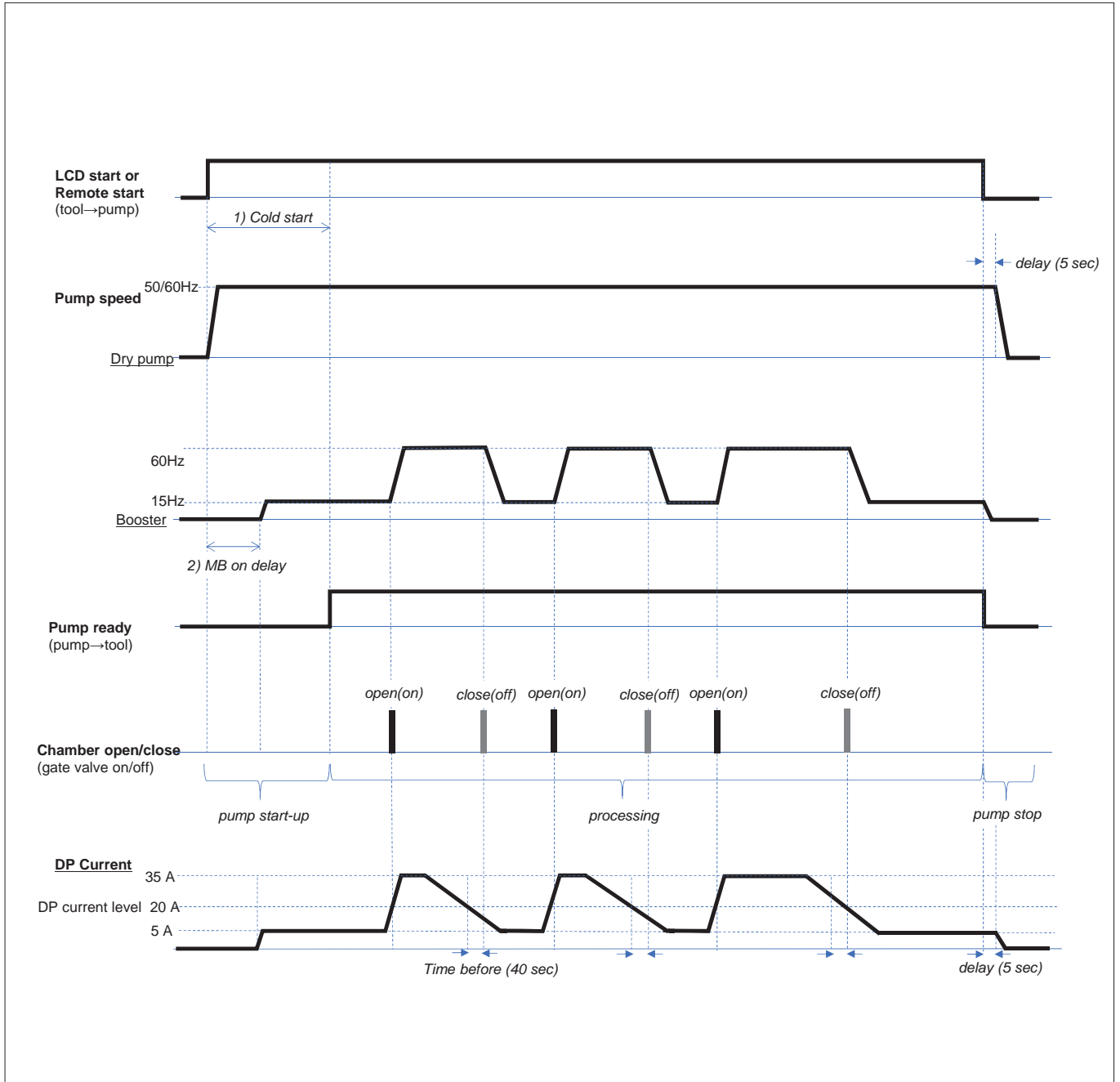

Standard DP current level	DP current level	40 A (200V)	20 A (400V)
	Time Before	40 sec	
** it depends on the process time, chamber capacity and end vacuum level			
Standard setting (time)	1) Cold start	900 sec	
	2) MB on delay	30 sec	

# Maintenance



CAUTION

In case the vacuum system has conveyed gases that have been contaminated with foreign materials that are dangerous to health, the oil and condensates will also be contaminated.

These foreign materials can infiltrate the pores, recesses and other internal spaces of the vacuum system.

Danger to health when the vacuum system is dismantled.

Danger to the environment.

Always wear protective clothing when carrying out maintenance work.

Before any maintenance work, the inlet and outlet piping as well as the vacuum system itself must be flushed with nitrogen.



CAUTION

Only authorised personnel may carry out dismantling work on the vacuum system. Before work begins, the operator of the vacuum system must fill in a form or a "Declaration Regarding Contamination of Equipment and Components" that provides information on possible dangers and appropriate measures. If this form has not been filled in completely and signed, the vacuum system may not be dismantled.



CAUTION

Before maintenance work is started, a safety area of at least 610 [mm] around the machine must be set up.



CAUTION

The surface temperature of the vacuum system can exceed 50°C when the vacuum system is in operation.

Danger of burns!

Before starting maintenance work, make sure that the vacuum system has been switched off and that it cannot be switched on again accidentally. Follow the shutdown procedure in the section "Lock Out/ Tag Out procedure" depending on the needs of maintenance:

- in REMOTE mode, the start/ stop drive of the vacuum system passes through the main machine interface of the vacuum system (the one connected to TOOL) and the COMBI COBRA DS start simultaneously.
- in LOCAL mode, the start/ stop drive of the COMBI COBRA DS is done independently. For safety reasons, execute the start of the COMBI COBRA DS simultaneously.
- stop the vacuum system with the remote control (press on STOP button during 10s)
- press on emergency stop button
- switch off the main circuit breaker
- open the power box and switch off the circuit breakers
- switch off the customer's power supply
- switch off the water (inlet first, then outlet) and nitrogen quick connections (cooling of the pumps is quickly done by not switching off the water connections).
- depending on the maintenance type, let the vacuum system cool in order to avoid burn (rapid cooling of the vacuum pump wished or not)
- put the label or warning board "Maintenance processing" on or next to the vacuum system



CAUTION

The oil temperature can reach a value of 90°C!

Danger of burns!

- Make sure that the oil circuit and the coolant circuit have been emptied before moving the vacuum system
- Make sure that there are no cleaning tools in the vacuum system anymore according to local and national regulations

Before pulling off the different connections, make sure that the intake and exhaust lines of the vacuum system correspond to atmospheric pressure.

When the maintenance work has been finished, follow the procedure "Safety Lockout Procedure":

- take off the label or warning board "Maintenance processing"
- check the cooling liquid and oil levels according to the chapters "Checking the oil level"
- open the power box cover and check that the thermal relays are on position "ON"
- close the cover
- release the emergency stop button and the lock
- switch on the main circuit breaker
- switch on the water (outlet first, then inlet) and nitrogen quick connections
- make sure that the "Necessary installation instructions" are followed
- start the vacuum system with the LCD or interface box (press on START button)

## Maintenance program

**NOTE:** The maintenance intervals depend on the operating conditions. The following intervals are basic values, which can be shortened or lengthened depending on operating conditions. In especially difficult operating conditions such as, for example, a very dusty environment the maintenance intervals must be shortened considerably.

### Daily:

- Check the oil level and the colour of the oil (see "Checking the oil")
- Check the level of the cooling liquid (see "Checking the cooling liquid")
- Check the cooling water (see "Checking the cooling water")
- Check the nitrogen flow (see "Checking the nitrogen")

### Weekly:

- Inspect the vacuum system for oil leaks - if there are leaks, repair the vacuum system (Busch)
- Inspect the vacuum system for leaks of cooling liquid - if there are leaks, repair the vacuum system (Busch)
- Inspect the vacuum system for oil cooling water - if there are leaks, repair the vacuum system (Busch)

### Monthly:

In the case of operation in a dusty environment:

- ◆ Make sure that the operating room is clean and free of dust; clean if necessary
- Make sure that the vacuum system has been switched off and that it cannot be switched on again accidentally
- Check the electrical connections
- Carry out a visual inspection of the vacuum system

## Yearly:

- Make sure that the vacuum system has been switched off and that it cannot be switched on again accidentally

If the intake is equipped with a sieve:

- ◆ Check the sieve at the intake and clean if necessary
- Check the measuring and safety equipment for working order

If the discharge is equipped with a sound absorber:

- ◆ Clean the sound absorber

If the discharge is equipped with a leak-protection non-return valve:

- ◆ Clean the leak-protection non-return valve
- Drain the cooling liquid (see "Draining the cooling liquid")

If the cooling water line is equipped with a filter:

- ◆ Check the filter and clean or replace if necessary
- Check the seals and replace if necessary
- Check the intake and discharge lines and clean or replace if necessary

## Every 16000 hours of operation, at the latest after 4 years:

- Drain the oil (see "Draining the oil")
- Main inspection of the vacuum system (Busch)

## Lock Out/ Tag out procedure

- Stop the vacuum system with the remote control (press on STOP button during 10s)
- Switch off the main circuit breaker (possibility of installing a lock)
- Press on emergency stop button
- Switch off the customer's power supply
- Switch off the water (inlet first, then outlet) and nitrogen quick connections
- Put the label or warning board "Maintenance processing" on or next to the vacuum system

## Safety Lockout procedure

- Take off the label or warning board "Maintenance processing"
- Check the cooling liquid and oil levels according to the chapters "Checking the oil level" and "Checking the cooling liquid level"
- Open the power box cover and check that the thermal relay is in manual reset position
- Close the cover
- Release the emergency stop button
- Switch on the main circuit breaker
- Switch on the water (outlet first, then inlet) and nitrogen quick connections
- Make sure that the "Necessary installation instructions" are followed
- Start the vacuum system with the remote control (press on START button)

## Checking the oil

### Checking the oil level

- Make sure that the vacuum pump has been switched off and that it cannot be switched on again accidentally
- Indication of the oil level on the various oil sight glasses

#### COBRA NS (DP) vacuum pump

If the oil level does not reach the target circle:

- ◆ Top up with oil (see "Refilling oil")

If the oil level exceeds the target circle:

- ◆ Check the condensate drain
- Drain the oil (see "Draining the oil")

#### WY (MB) rotary lobes vacuum pump

If the oil level does not reach the target circle:

- ◆ Top up with oil (see "Refilling oil")

If the oil level exceeds the target circle:

- ◆ Check the condensate drain
- Drain the oil (see "Draining the oil")

## Filling in new oil

#### COBRA NS (DP) vacuum pump

- Prepare the quantity of oil needed (see "Oil type/ quantity")



WARNING

The use of chemically contaminated or polluted oil can lead to hazardous pump conditions which could cause personal injury.

**NOTE:** The quantity of oil specified in the installation handbook is of informative nature only. Check the oil level with the help of the various oil sight glasses (OSG 1, OSG 2) on the vacuum system.

- Make sure that the drain plugs have been fitted properly and that they do not leak



CAUTION

Only fill in oil through the oil filler opening.

- Unscrew the oil filler cap (OFP)
- Fill in oil in to the target circle of the oil sight glasses

#### Oil level, pump not operating

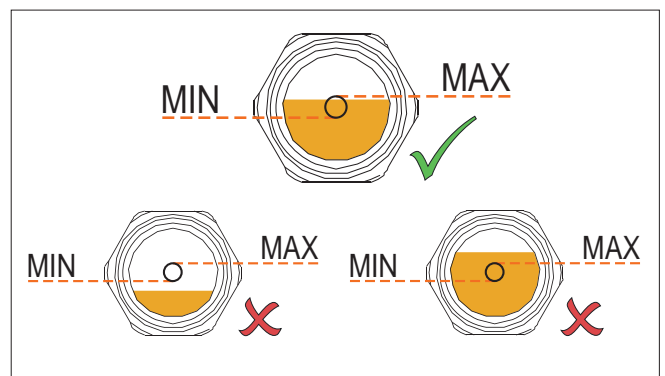

- Make sure that the oil level is in the target circle of the oil sight glasses
- Make sure that the seals of the filler cap are not damaged and that they sit properly. Replace if necessary.
- Screw on the filler cap again

## WY (MB) rotary lobes vacuum pump

- Prepare the quantity of oil needed (see "Oil type/ quantity")

**NOTE:** The quantity of oil specified in the installation handbook is of informative nature only. Check the oil level with the help of the various oil sight glasses on the vacuum system.

- Make sure that the drain plugs have been fitted properly and that they do not leak



CAUTION

Only fill in oil through the oil filler opening.

- Unscrew the oil filler cap (OFP)
- Fill in oil in to the target circle of the oil sight glass

### Oil level, pump not operating

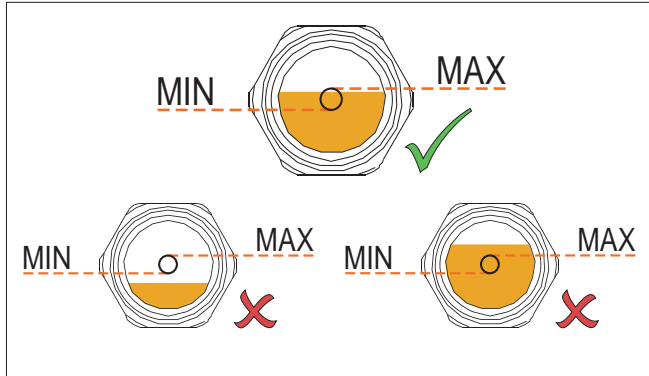

- Make sure that the oil level is in the target circle of the oil sight glasses
- Make sure that the seals of the filler cap are not damaged and that they sit properly. Replace if necessary.
- Screw on the filler cap again

## Checking the colour of the oil

**NOTE:** The oil must be clear and transparent. A permanent milky colour is an indication for contamination by foreign bodies. A dark colour is an indication for oil that has been chemically altered or contaminated by foreign bodies.



WARNING

Dark colored oil may indicate a hazardous pump condition which could cause personal injury.

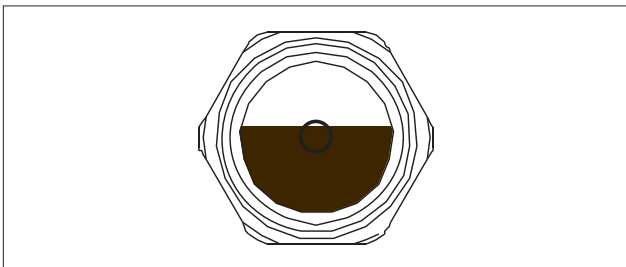

If dark oil similar to the example shown is observed, you have to contact the Busch Customer Service without delay.

## Oil change



WARNING

If the vacuum system has pumped gases that were contaminated with foreign bodies that are hazardous to health, the oil is also contaminated with these foreign bodies.

There is a health hazard when changing contaminated oil.

There is also a danger to the environment.

Wear protective clothing when replacing contaminated oil.

Contaminated oil must be treated specially and must be disposed of according to applicable regulations.

## Draining used oil

**NOTE:** After switching off the vacuum system at normal operating temperature wait no more than 20 minutes before the oil is drained.

- Make sure that the vacuum system is switched off and cannot accidentally be switched on again
- Make sure that the vacuum system is vented to atmospheric pressure

### COBRA NS (DP) vacuum pump

- Put a drain tray underneath the oil drain plugs (ODP)
- Unscrew the oil drain plugs (ODP)
- Carefully remove the drain plugs
- Drain the oil
- Because of wear and tear on the seal replace the current drain plugs with new ones

When the oil flow has stopped:

- Close the oil drain plugs (ODP)
- Switch on the vacuum pump for a few seconds
- Make sure that the vacuum pump is switched off and cannot accidentally be switched on again
- Carefully remove the oil drain plugs again and drain any remaining oil
- Check that no metal swarf sticks to the magnet of the drain plug, clean if necessary
- Refit the oil drain plugs and tighten up
- Dispose of the used oil in compliance with applicable regulations



CAUTION

Because the ends of the drain plugs are magnetic, metal swarf can stick to them. Always clean away this swarf when removing the drain plugs.

Because of wear and tear of the seals, it is recommended to replace the drain plugs whenever the oil is changed.

### WY (MB) rotary lobes vacuum pump

- Place a container under the oil drain plugs (ODP)
- Unscrew the oil drain plugs (ODP)
- Drain the oil

When oil stops running out:

- ◆ Close the oil drain plugs (ODP) again
- Switch on the vacuum system and let it run for a few seconds
- Make sure that the vacuum system has been switched off and that it cannot be switched on again accidentally
- Unscrew the oil drain plugs again and drain the remaining oil

- Make sure that the seals of the drain plugs are not damaged and that they sit properly. Replace them if necessary.
- Screw on the drain plugs again
- Dispose of the used oil according to applicable environmental protection regulations

## Checking the cooling liquid

### Checking the level of the cooling liquid

- Make sure that the vacuum system has been switched off and that it cannot be switched on again accidentally
- Check the level of the cooling liquid in the cylinder upper plate
  - ◆ Unscrew and remove the purge cap (CLV1) on cylinder upper plate
  - ◆ Cooling liquid must be just at the level of the purge cap (space in the expansion vessel).
- Check the level of the cooling liquid in the cylinder endplate B-side (opposite side of the motor)
  - ◆ Unscrew, but do not remove completely the purge cap (CLV2)
  - ◆ The level is OK only if the cooling liquid try to flow out.



#### WARNING

Be carefull, the cooling liquid quantity which could flow, could be important.

If the level is below:

- ◆ Top up with cooling liquid (see "Refilling cooling liquid")

### Filling in new cooling liquid

- Prepare the quantity of cooling liquid needed (see "Cooling liquid type/ quantity")

**NOTE:** The quantity of cooling liquid specified in the installation handbook is of informative nature only.

- Make sure that the drain plugs have been fitted properly and that they do not leak
- Unscrew purge cap (CLV 1) on cylinder upper plate
- Check the level of the cooling liquid: if the cooling liquid level is at the purge cap on cylinder upper plate, do not unscrew the purge cap on cylinder endplate B-side as the cooling liquid will flow outside, otherwise follow the procedure
- Unscrew purge cap (CLV 2) on cylinder endplate B-side
- Unscrew the filler cap for the cooling liquid
- Fill in again by filler hole until cooling liquid arrives at the level of the purge cap of cylinder endplate B-side
- Stop fill in
- Close the purge cap on cylinder upper plate
- Make sure that the seals of the filler cap are not damaged and that they sit properly. Replace if necessary.
- Screw on the filler plug again
- Wipe cooling liquid that may have run on outside surfaces of vacuum system

### Refilling cooling liquid

Cooling liquid does not normally have to be refilled outside the recommended cooling liquid change intervals.

- Make sure that the vacuum system has been switched off and that it cannot be switched on again accidentally
- Unscrew the filler cap (CLF) for the cooling liquid
- Check the level of the cooling liquid: if the cooling liquid level is at the purge cap on cylinder upper plate, do not unscrew the purge cap on cylinder endplate B-side as the cooling liquid will flow outside otherwise follow the procedure

- Open purge cap (CLV1) on cylinder upper plate and purge cap (CLV2) on cylinder endplate B-side
- Fill in by filler hole until cooling liquid flows by purge cap on cylinder endplate B-side
- Stop fill in
- Close the purge cap on cylinder endplate B-side
- Fill in again by filler hole until cooling liquid flows by purge cap of cylinder upper plate
- Close the purge cap of cylinder upper plate
- Screw on the cooling liquid filler cap again
- If liquid has run on to the outside surfaces of the vacuum system, wipe it off

### Draining the cooling liquid

- Make sure that the vacuum system has been switched off and that it cannot be switched on again accidentally
- Make sure that the vacuum system has been adjusted to atmospheric pressure
- Place a container under the drain plug (CLD) for the cooling liquid
- Unscrew drain plug of cooling liquid
- Unscrew filling cap on cylinder upper plate
- Unscrew purge cap on cylinder endplate B-side

When cooling liquid stops running out:

- Screw purge caps
- Close the drain plug for the cooling liquid
- Make sure that the seals of the filler cap are not damaged and that they sit properly. Replace if necessary.
- Dispose of the used cooling liquid according to applicable environmental protection regulations

## Checking the cooling water

### Checking the cooling water flow

- Checking the cooling water flow regularly

If the flow drops, check for leaks

- ◆ Make sure that the specifications of the cooling water are followed

## Checking the nitrogen

### Checking the nitrogen flow

- Checking the nitrogen flow regularly (only when DP runs)

If the flow drops, check for leaks

- ◆ Make sure that the specifications of the nitrogen are followed

## Checking the current consumption

- ◆ Check the current intensity of the motors of the DP and MB vacuum pumps

An increased intensity is an indication for a fault

## Checking the sound silencer (accessory)

- Make sure that the condensate does not collect at the exhaust of the vacuum system
- Drain the condensate at the drain opening and collect it in a container
- Dispose of the condensate according to applicable environmental protection regulations
- Check the sound absorber regularly and clean it if necessary

## Checking the leak-protection non-return valve (accessory)

- Check the leak-protection non-return valve regularly and clean it if necessary



CAUTION

Wear protective clothing when carrying out maintenance work on the sound absorber and leak-protection non-return valve.

There could still be residues of contamination.

## Overhaul



CAUTION

Inappropriate maintenance work on the vacuum system can damage the vacuum system.

Danger of explosion!

If requirements are not met, the vacuum system may not be switched on!

Should work exceed the dismantling work described in this handbook, it may only be carried out by authorised persons.



WARNING

If the vacuum system has pumped gases that were contaminated with foreign bodies that are hazardous to health, the oil and condensate are also contaminated with these foreign bodies.

These foreign bodies can penetrate into pores, openings and other internal parts of the vacuum system.

There is a health hazard when dismantling the vacuum system.

There is also a danger to the environment.

Prior to shipping, the vacuum pump must imperatively be decontaminated and the degree of contamination must be documented in a declaration of decontamination ("Declaration of Decontamination"), which can be downloaded from [www.buschvacuum.com](http://www.buschvacuum.com).

Busch service will only accept vacuum pumps that come with a completely filled in and legally binding signed form.

## Removal from service

### Temporary removal from service

Before disconnecting the intake and exhaust lines and switching off the cooling water and nitrogen lines, make sure that the lines have adjusted to atmospheric pressure

### Recommissioning



CAUTION

If the vacuum system was switched off for a longer period of time, the rotors of the COBRA NS vacuum pump can be jammed.

Turn the screw rotors by hand.

- Make sure that the various protective elements, stoppers or adhesive tapes have been removed
- Switch on the vacuum system by following the procedure described in the chapter "Installation and start-up"

## Dismantling and disposal



WARNING

If the vacuum system has pumped gases that were contaminated with foreign bodies that are hazardous to health, the oil and condensate are also contaminated with these foreign bodies.

These foreign bodies can penetrate into pores, openings and other internal parts of the vacuum system.

There is a health hazard when dismantling the vacuum system.

There is also a danger to the environment.

Protective clothing must be worn when dismantling the vacuum system.

The vacuum system must be decontaminated as far as possible by the user before delivery. The state of decontamination must be documented in the "Declaration Regarding Contamination of Equipment and Components" (form to be found in this handbook or downloaded from [www.buschvacuum.com](http://www.buschvacuum.com)).

Dispose of the used oil and condensate according to applicable environmental protection regulations.

When the product has reached the end of its lifetime:

- decontaminate the vacuum system



CAUTION

Dismantling work must be carried out by authorised personnel. Before work begins, the operator of the vacuum system must fill in a form or a "Declaration of Decontamination" that provides information on possible dangers and appropriate measures.

If this form has not been filled in completely and signed, the vacuum system may not be dismantled.

- drain the oil
  - ◆ dispose of the oil according to local environmental protection regulations
- drain the cooling liquid
  - ◆ dispose of the cooling liquid according to local environmental protection regulations
- begin dismantling the vacuum system



CAUTION

Wear protective clothing when carrying out dismantling work.

- ◆ dispose of the vacuum system as scrap metal
- dispose of the individual parts of the machine according to local regulations

A lithium battery is present inside the PLC:

eliminate the lithium battery according to local and national regulations in place, relating to environment

# Oil type/ quantity

## Oil type

- Make sure that the oil type corresponds to specification:
  - Busch YLC 250 B, Art. No. 0831 131 400 (0,5 l  $\cong$  1 kg)



**WARNING**

The use of chemically contaminated or polluted oil can lead to hazardous pump conditions which could cause personal injury.

## Oil quantity

The quantity of oil specified in the following table is of informative nature only. Check the oil level with the help of the various oil sight glasses on the vacuum system.

Quantity [l]	Motor side (A)	Inlet side (B)
DP: NS 600 C	0,8	0,8
Quantity [l]	Rear sided lobes	Motor sided lobes
MB: WY 075	6,5	6,0

## Cooling liquid type/ quantity (DP only)

### Cooling liquid type

- Make sure that the cooling liquid type corresponds to specifications :

Specifications	Zitrec M-25 (ready-to-use)	
	20 litres can	5 litres can
	part no. 0831 238 761	part no. 0831 563 469

### Cooling liquid quantity

The quantity of cooling liquid specified in this instructions manual is of informative nature only. Respect the procedure of filling the cooling liquid.

Quantity	Zitrec M-25 (already mixed ready-to-use)
NS 600 C	approx. 26 litres



#### CAUTION

The proportion of pure glycol and water for the cooling liquid corresponds to a percentage of 40% pure glycol and 60% water. It is therefore not necessary to prepare the mix before use. But when using pure glycol, it is imperative to prepare the mix prior to filling the pump and to respect this proportion.



# Technical data

Technical data				DS 8163 B
Nominal suction capacity		60 Hz	m <sup>3</sup> /h (cfm)	7385 (4347)
Ultimate pressure			Torr mbar	7,5 x 10 <sup>-4</sup> 1,0 x 10 <sup>-3</sup>
Electric power capacity at ultimate pressure		60 Hz	kW (MB : 60 Hz) kW on idle mode (15 Hz)	31 28
Motor rating	DP MB	60 Hz 60 Hz	kW	3 x 15 15
Nominal motor speed	DP	60 Hz	min <sup>-1</sup>	3600
Nominal motor speed with frequency inverter	MB	60 Hz	min <sup>-1</sup>	3600
Noise level (EN ISO 2151)		50 Hz 60 Hz	dB(A) dB(A)	< 75
Ambient temperature			°C (°F)	0 - 40 (32 - 104)
Maximal counter pressure	Discharge		bar	0.2
Cooling water requirement (motors cooling)			l/ min	min. 29
Cooling water pressure			bar/ ΔP	2 ... 5
Cooling water temperature			°C	10 - 25°C
Nitrogen requirement	approx.		l/ min	3 x 0 - 200
Nitrogen overpressure			bar	1,5
Weight	approx.		kg	3320

---

# EU Declaration of Conformity

This Declaration of Conformity and the CE-mark affixed to the nameplate are valid for the machine within the Busch scope of delivery. This Declaration of Conformity is issued under the sole responsibility of the manufacturer. When this machine is integrated into a superordinate machinery the manufacturer of the superordinate machinery (this can be the operating company, too) must conduct the conformity assessment process for the superordinate machine or plant, issue the Declaration of Conformity for it and affix the CE-mark.

The manufacturer

**Busch Manufacturing Korea, Ltd.**  
189-51, Soicheon-ro, Majang-myun  
Icheon-si, Gyunggi-do, 467-813  
Republic of Korea

declares that the machine(s): **COBRA DS 8163 B**

fulfil(s) all the relevant provisions from European directives:

- 'Machinery' 2006/42/EC
- 'Electromagnetic Compatibility' 2014/30/EU
- 'RoHS' 2011/65/EU Restriction of the use of certain hazardous substances in electrical and electronic equipment (incl. all related applicable amendments)

and comply(-ies) with the following designated standards that have been used to fulfil those provisions:

Standard	Title of the Standard
EN ISO 12100 : 2010	Safety of machinery - Basic concepts, general principles of design
EN ISO 13857 : 2019	Safety of machinery - Safety distances to prevent hazard zones being reached by the upper and lower limbs
EN 1012-1 : 2010 EN 1012-2 : 1996 + A1 : 2009	Compressors and vacuum pumps - Safety requirements - Part 1 and Part 2
EN ISO 2151 : 2008	Acoustics - Noise test code for compressors and vacuum pumps - Engineering method (grade 2)
EN 60204-1 : 2018	Safety of machinery - Electrical equipment of machines - Part 1: General requirements
EN IEC 61000-6-2 : 2019	Electromagnetic compatibility (EMC) - Generic standards. Immunity for industrial environments
EN IEC 61000-6-4 : 2019	Electromagnetic compatibility (EMC) - Generic standards. Emission standard for industrial environments
EN ISO 13849-1 : 2015 <sup>(1)</sup>	Safety of machinery - Safety-related parts of control systems - Part 1: General principles for design

<sup>(1)</sup> In case control systems are integrated.

Legal person authorized to compile the technical file  
and authorized representative in the EU  
(if the manufacturer is not located in the EU):

Busch Dienste GmbH  
Schauinslandstr. 1  
DE-79689 Maulburg

Icheon-si, 14.05.2021



**Seung-hwa Yoo, General Director**

# UK Declaration of Conformity

This Declaration of Conformity and the UKCA-mark affixed to the nameplate are valid for the machine within the Busch scope of delivery. This Declaration of Conformity is issued under the sole responsibility of the manufacturer. When this machine is integrated into a superordinate machinery the manufacturer of the superordinate machinery (this can be the operating company, too) must conduct the conformity assessment process for the superordinate machine or plant, issue the Declaration of Conformity for it and affix the UKCA-mark.

The manufacturer

**Busch Manufacturing Korea, Ltd.**  
189-51, Soicheon-ro, Majang-myun  
Icheon-si, Gyunggi-do, 467-813  
Republic of Korea

declares that the machine(s): **COBRA DS 8163 B**

fulfil(s) all the relevant provisions from UK legislations:

- Supply of Machinery (Safety) Regulations 2008
- Electromagnetic Compatibility Regulations 2016
- Restriction of the use of certain hazardous substances in electrical and electronic equipment Regulations 2012

and comply(-ies) with the following designated standards that have been used to fulfil those provisions:

Standard	Title of the Standard
BS EN ISO 12100 : 2010	Safety of machinery. Basic concepts, general principles of design. Risk assessment and risk reduction.
BS EN ISO 13857 : 2019	Safety of machinery - Safety distances to prevent hazard zones being reached by the upper and lower limbs.
BS EN 1012-1 : 2010 BS EN 1012-2 : 1996 + A1 : 2009	Compressors and vacuum pumps. Safety requirements. Air compressors and vacuum pumps.
BS EN ISO 2151 : 2008	Acoustics - Noise test code for compressors and vacuum pumps - Engineering method (grade 2)
BS EN 60204-1 : 2018	Safety of machinery. Electrical equipment of machines. General requirements.
BS EN IEC 61000-6-2 : 2019	Electromagnetic compatibility (EMC) - Generic standards. Immunity standard for industrial environments.
BS EN IEC 61000-6-4 : 2019	Electromagnetic compatibility (EMC) - Generic standards. Emission standard for industrial environments.
BS EN ISO 13849-1 : 2015 <sup>(1)</sup>	Safety of machinery. Safety-related parts of control systems. General principles for design.

<sup>(1)</sup> In case control systems are integrated.

Legal person authorized to compile the technical file  
and importer in the UK  
(if the manufacturer is not located in the UK):

Busch (UK) Ltd  
30 Hortonwood  
Telford - UK

Icheon-si, 14.05.2021



**Seung-hwa Yoo, General Director**

# Busch

## Vacuum Solutions

We shape vacuum for you.

### Argentina

info@busch.com.ar

### Australia

sales@busch.com.au

### Austria

busch@busch.at

### Bangladesh

sales@busch.com.bd

### Belgium

info@busch.be

### Brazil

vendas@buschdobrasil.com.br

### Canada

info@busch.ca

### Chile

info@busch.cl

### China

info@busch-china.com

### Colombia

info@buschvacuum.co

### Czech Republic

info@buschvacuum.cz

### Denmark

info@busch.dk

### Finland

info@busch.fi

### France

busch@busch.fr

### Germany

info@busch.de

### Hungary

busch@buschvacuum.hu

### India

sales@buschindia.com

### Ireland

sales@busch.ie

### Israel

service\_sales@busch.co.il

### Italy

info@busch.it

### Japan

info@busch.co.jp

### Korea

busch@busch.co.kr

### Malaysia

busch@busch.com.my

### Mexico

info@busch.com.mx

### Netherlands

info@busch.nl

### New Zealand

sales@busch.co.nz

### Norway

post@busch.no

### Peru

info@busch.com.pe

### Poland

busch@busch.com.pl

### Portugal

busch@busch.pt

### Romania

office@buschromania.ro

### Russia

info@busch.ru

### Singapore

sales@busch.com.sg

### South Africa

info@busch.co.za

### Spain

contacto@buschiberica.es

### Sweden

info@busch.se

### Switzerland

info@buschag.ch

### Taiwan

service@busch.com.tw

### Thailand

info@busch.co.th

### Turkey

vakutek@ttmail.com

### United Arab Emirates

sales@busch.ae

### United Kingdom

sales@busch.co.uk

### USA

info@buschusa.com